



RACK VINTAGE ÓREGON

ATENÇÃO/ ATTENTION / ATENCION

VÍDEO DE MONTAGEM DISPONÍVEL NO SITE / ASSEMBLY VIDEO AVAILABLE ON THE SITE
VÍDEO DE MONTAJE DISPONIBLE EN EL SITIO

www.olivar.com.br

DIMENSÕES DO PRODUTO / PRODUKT DIMENSIONS / DIMENSIONS PRODUCT - **WxDxH / LxDxA - 1620 X 388X 548MM**



Vídeo de Montagem
Assembly video
VÍDEO DE MONTAJE

ATENÇÃO/ ATENCION/ ATTENTION

ESTE PRODUTO NÃO PODE SER ARRASTADO.
THIS PRODUCT MUSTNOT BE DRAGGED.
ESTE PRODUCTO NO SE PUEDE ARRASTRAR

TV 49"

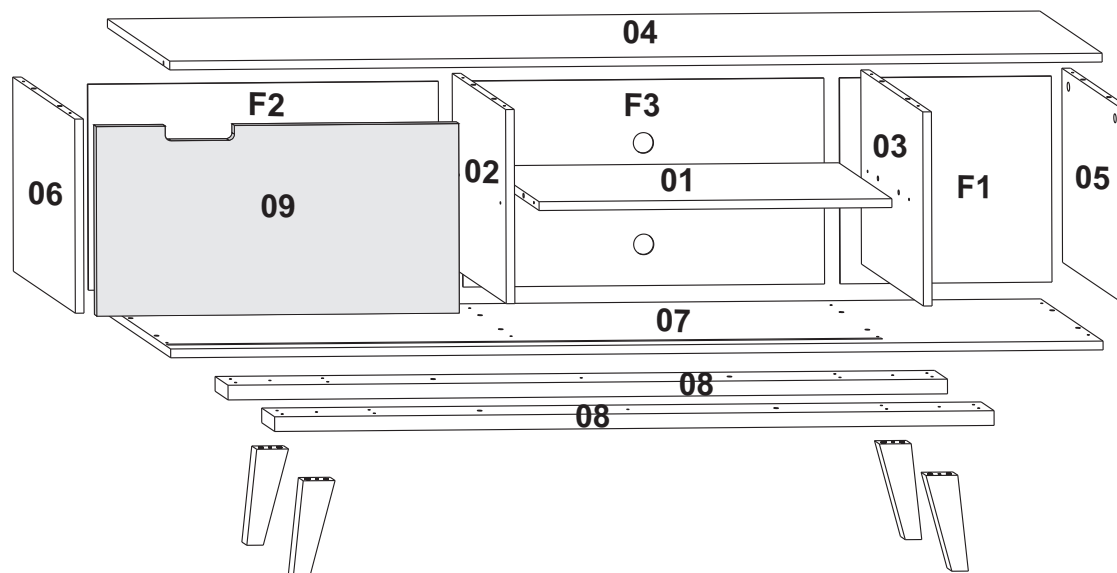
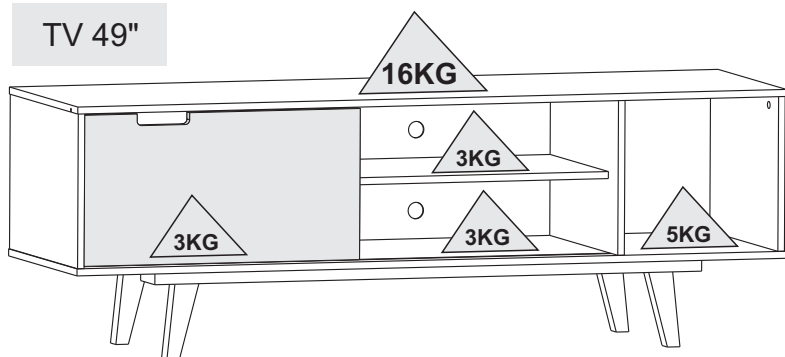

CUIDADOS ESPECIAIS

LIMPEZA- Pano limpo umedecido em água e sabão neutro.
BRILHO- Flanela seca.

SPECIAL CARE

CLEANING- Clean cloth moistened with water and mild soap.
SHINE- Dry cloth.

CUIDADOS ESPECIALES:

LIMPIEZA- Paño limpio humedecido con agua y un jabón suave.
BRIGHT- Flanela seco.

ATENÇÃO / ATTENTION / ATENCION

Nunca utilizar óleos, lustra móveis; produtos abrasivos, saponáceos, esponja de aço e outros.

Never use oils, polish furniture , abrasive products, soaps, steel sponge and others.

Nunca use aceites, pulimentos; abrasivos, jabones, esponja de acero y otros.

MONTAR O PRODUTO SOBRE A EMBALAGEM, EVITANDO DANOS NA PINTURA. ACONSELHAMOS QUE A MONTAGEM DO PRODUTO SEJA POR UM PROFISSIONAL.

SETUP THE PRODUCT ON TOP OF THE PACKAGING, AVOIDING DAMAGE TO THE PAINT. WE RECOMMEND THAT THE INSTALLATION IS DONE BY A PROFESSIONAL.

MONTAR EL PRODUCTO EN EL PAQUETE, EVITAR LESIONES EN PINTURA. AVISAMOS QUE EL MONTAJE DEL PRODUCTO SEA UN PROFESIONAL.



Ferramentas necessárias / Necessary tools / Herramientas Necesarias
(não fornecidas) (not provided) (No proporcionadas)

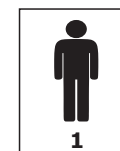

1

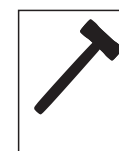
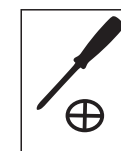

**MEDIDA UTILIZADA EM MM /
UNIT MEASURE USED
IS MILLIMETERS (MM)**

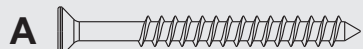

PF / SCREW / TORNILLO
4.0X40(MM) CH (12)



GARRA / JONT METAL PLATE
EMBRAGUES (06)

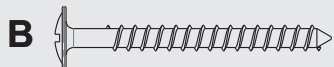

PF / SCREW / TORNILLO
3.5x25 (MM) FL (18)

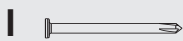

PREGO / NAIL / CLAVO
8X8 (MM) (35)



CAVILHA / WOODEN DOWEL
TARUGO 8X30 (MM) (32)



AMORTECEDOR/
PU BUMPER/ PARACHOQUES
POLIURETANO (08)

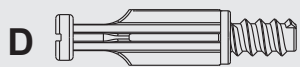

PINO MINIFIX /
MINI FIX SCREW 32 (MM) (08)

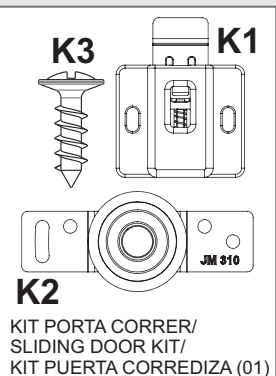

KIT PORTA CORRER/
SLIDING DOOR KIT/
KIT PUERTA CORREDIZA (01)



TAMBOR MINIFIX /
MINI FIX ROUND NUT
15 MM (08)



TAPA FURO /
MINI FIX COVER CAP(08)



TAPA FURO/
HOLER STIKER/
TAPA AGUGERO 8 (MM) (04)



PÉ MADEIRA/ WOOD FOOT VINTAGE
PIES MADERA VINTAGE 170 MM (04)



PF / SCREW / TORNILLO
6.0X80(MM) CH (04)

ITEM		DESCRIÇÃO DA PEÇAS / DESCRIPTION OF PARTS / UNIT MEASURE USED IS MILLIMETERS (MM)				CORES/ COLORS/ COLORES		
CÓDIGO CODE	Nº	NOME/NAME/NOMBRE	MEDIDAS / MEASURES (MM)	TIPO TYPE	QUANT AMOUNT CANTIDAD	BRANCO WHITE BLANCO	PRETO BLACK NEGRO	MEL FREIJÓ
11839	1	PRATELEIRA/ SHELF/ ESTANTE	613X328X15	MDP	01	1/05	1/07	1/18
11840	2	DIVISOR ESQUERDO/ LEFT DIVIDER	330X330X15	MDP	01	2/05	2/07	2/18
11841	3	DIVISOR DIREITO/ RIGHT DIVIDER	383X330X15	MDP	01	3/5	3/07	3/18
11843	4	TAMPO SUPERIOR/ HIGHER TOP	1620X385X15	MDP	01	4/5	4/07	4/18
11842	5	LATERAL DIREITA/ LEFT SIDE/ LADO IZQUIERDO	383X330X15	MDP	01	5/5	5/07	5/18
11838	6	LATERAL ESQUERDA/ LEFT RIHGT/ LADO DERECHO	383X330X15	MDP	01	6/5	6/07	6/18
11837	7	BASE	1620X385X15	MDP	01	7/5	7/07	7/18
11845	8	REFORÇO PÉ/ FOOT REINFORCEMENT/ REFUERZO PIE	1160X80X25	MDF	02	8/5	8/07	8/18
11844	9	PORTA CORRER/ SLIDING DOOR/ PUERTA CORREDIZA	630X322X15	MDF	01	9/5	9/07	
11846	F1	FUNDO TRÁS / BACK / TRASEIRO	609X350X3	TRI	01	F1/5	F1/07	F1/18
11847	F2	FUNDO TRÁS / BACK / TRASEIRO	368X350X3	TRI	01	F2/5	F2/07	F2/18
11848	F3	FUNDO TRÁS / BACK / TRASEIRO	628X350X3	TRI	01	F3/5	F3/07	F3/18
438	A	PF. / Screw / Tornillo 4,0x40 (MM) CH			12			
12774	B	PF. / Screw / Tornillo 3,5x35 (MM) CH			18			
137	C	Cavilha / Wooden Dowel / Tarugo 8x30(MM)			32			
532	D	Pino Minifix /Minifix Screw 32(MM)			08			
508	E	Tambor Minifix / Minifix Round Nut 15(MM)			08			
509	F	Tampa Minifix / Minifix Cover Cap 15(MM)			08	BCO		
7125							PTO	
511								CAFÉ
7687	G	Tapa Furo/Holer Stiker/ Tapa de Agugero 8 MM			04	BCO		
952							PTO	
254								CAFÉ
911	H	Garra/ Jont Metal Plate/ Embragues			06			
248	I	Prego / Nail / Clavo 8x8(MM)			35			
3441	J	Amortecedor/ Pu Bumber/ Parachoques			04			
9002	K	Kit porta de correr/ Sliding Door Kit			01			
10371	L	Trilho/ Rail Plastic 1218 MM			01			
12076	M	Pé Madeira Vintage/ Wood Foot Vintage/ Pies Madera Vintage 170 MM			04	MOG	MOG	MOG
12077								
11710	N	PF. / Screw / Tornillo 6,0x80 (MM) CH			04			
		Certificado Garantia			01			

**FIXAR PINO DE MINIFIX, TAMBOR E TAPA /
FIXING THE MINIFIX PIN, DRUM AND MINIFIX COVER
COLOQUE EL PINO E TAMBOR MINIFIX Y LA TAPA**

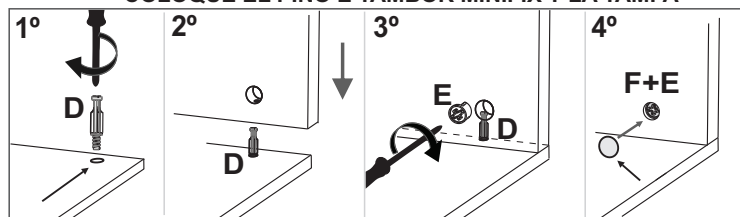

1

Obs: As peças pintadas nos passos são apenas ilustrativas.
The parts painted in the steps are illustrative only.
Las partes pintadas en los pasos son solo ilustrativas.

 Borda colorida fica na frente.
Colored edge is forward.
El borde de color está hacia adelante

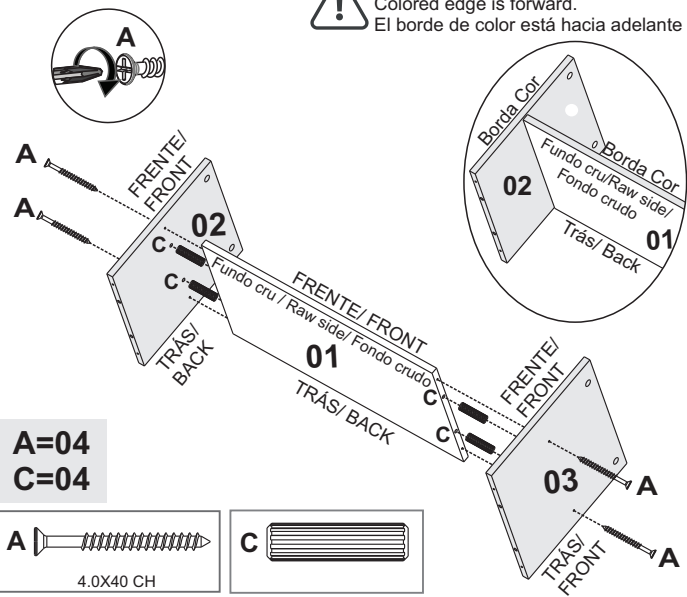

2

C=04
D=04
E=04
F=04

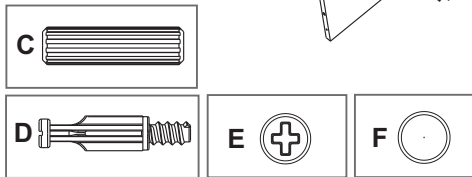

3

C=04
D=04
E=04
F=04

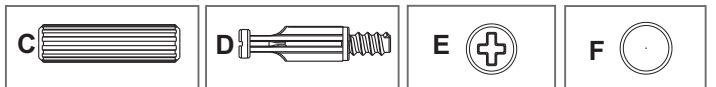

4

  Martelo de borracha
Rubber hammer
Martillo de goma

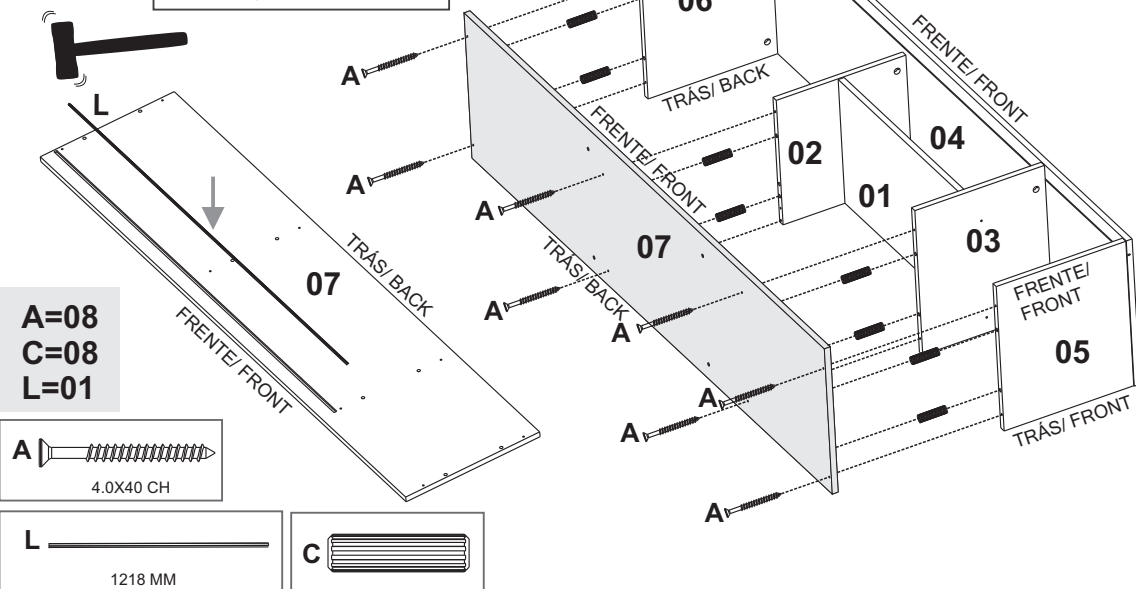

5

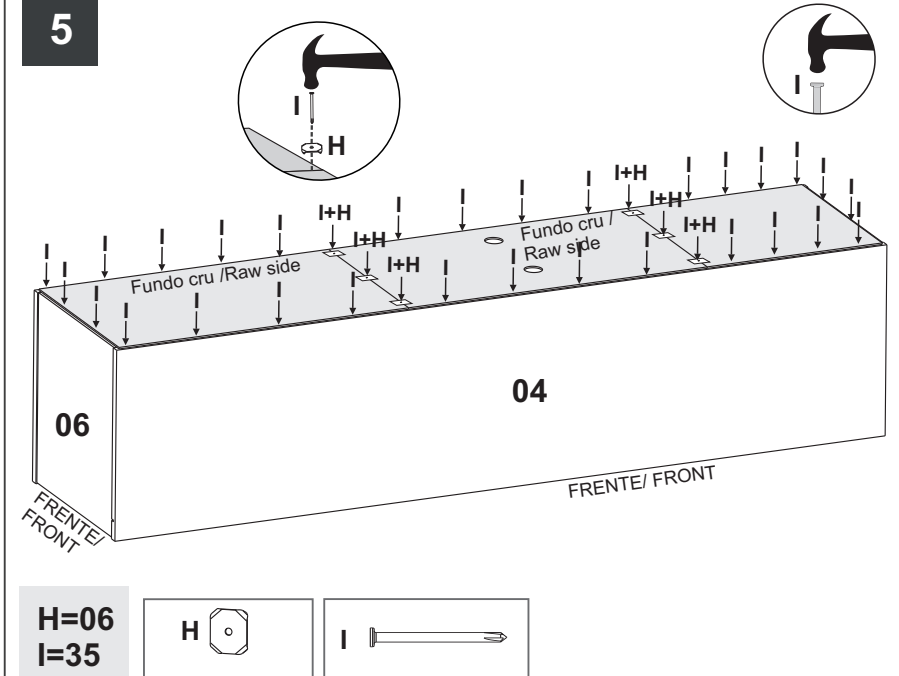

6

! FIXAÇÃO PÉS/ LEG FIXATION/ FIXACION PIES

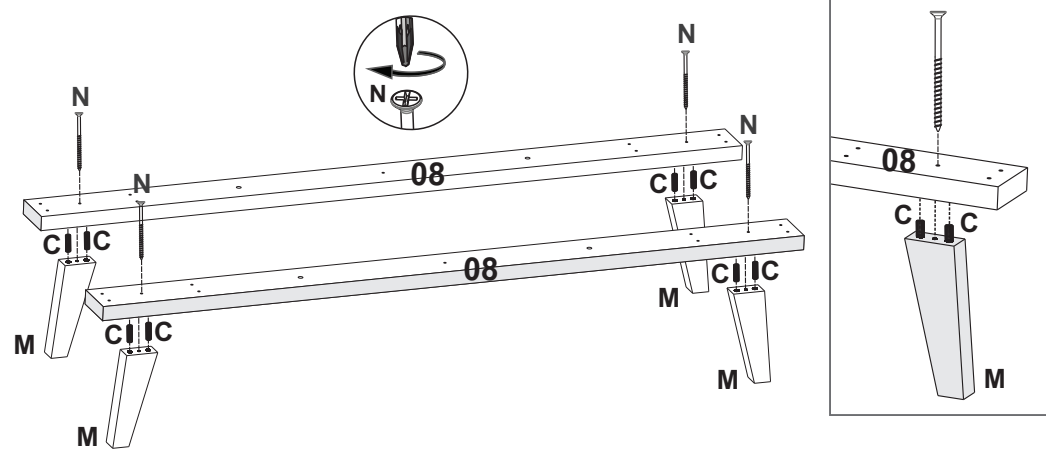

C=08
M=04
N=04

7

ATENÇÃO/ ATTENTION / ATENCION

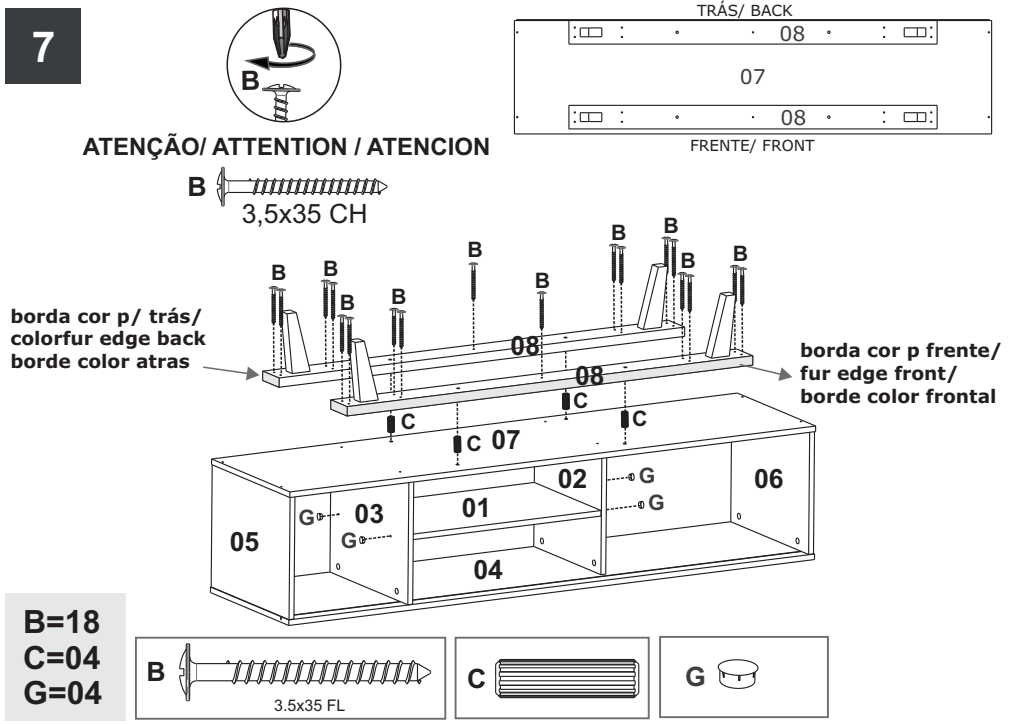

8

ATENÇÃO/ ATTENTION / ATENCION

ABAIXAR E ENCAIXAR/
 LOWER THE DEVICE
 FOR IT TO FIT IN
 ABAJAR E AJUSTAR

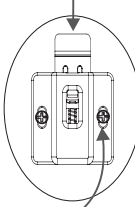

REGULAR O PARAFUSO/
 SCREWADJUSTMENT/
 AJUSTE EL TORNILLO

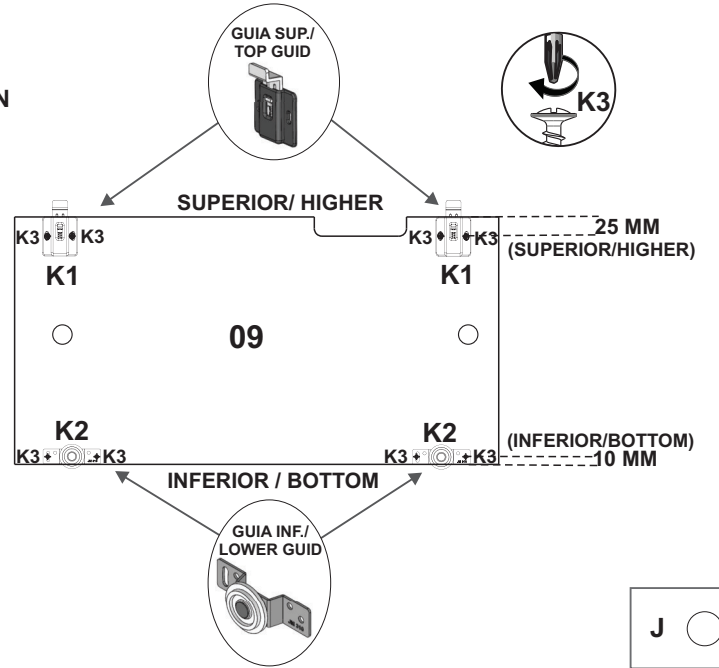

J=04
K1=02
K2=02
K3=08

