



# RACK RETRÔ COLOR

## ATENÇÃO/ ATTENTION / ATENCION

VÍDEO DE MONTAGEM DISPONÍVEL NO SITE / ASSEMBLY VIDEO AVAILABLE ON THE SITE

VÍDEO DE MONTAJE DISPONIBLE EN EL SITIO

[www.olivar.com.br](http://www.olivar.com.br)

DIMENSÕES DO PRODUTO / PRODUKT DIMENSIONS / DIMENSIONS PRODUCT - WxDxH / LxDxA - 1620 X 388 X 579 MM

### ATENÇÃO/ ATENCION/ ATTENTION

ESTE PRODUTO NÃO PODE SER ARRASTADO.  
THIS PRODUCT MUSTNOT BE DRAGGED.  
ESTE PRODUCTO NO SE PUEDE ARRASTRAR

PEÇAS NUMERADAS/ NUMBERED PARTS/  
PIEZAS NUMERADAS

EX: 1915X-X 05(peça/ piece/ pieza number)



Vídeo de Montagem  
Assembly video  
Video de Montaje

TV 48"

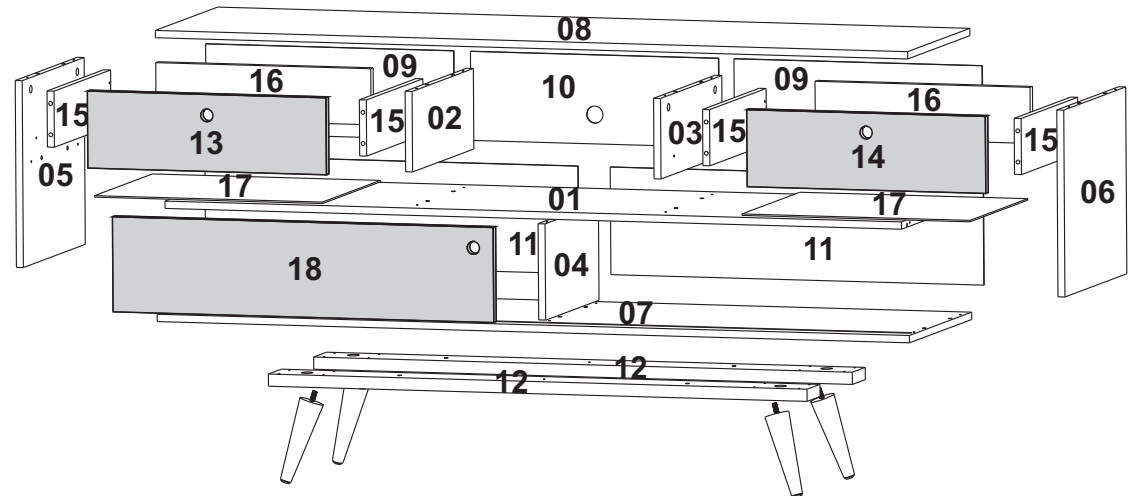
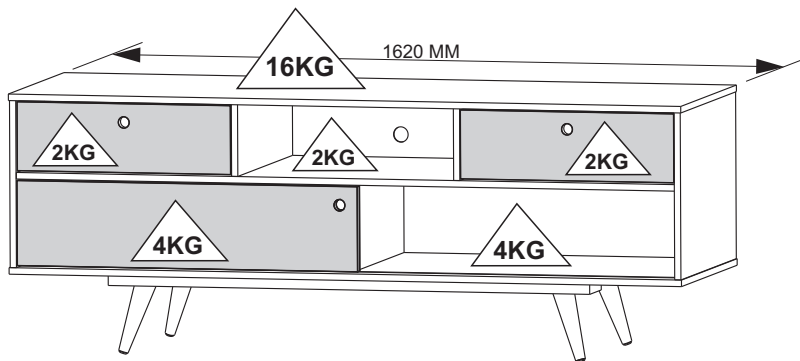

#### CUIDADOS ESPECIAIS

LIMPEZA- Pano limpo umedecido em água e sabão neutro.  
BRILHO- Flanela seca.

#### SPECIAL CARE

CLEANING-Clean cloth moistened with water and mild soap.  
SHINE- Dry cloth.

#### CUIDADOS ESPECIALES:

LIMPIEZA- Paño limpio humedecido con agua y un jabón suave.  
BRIGHT- Franela seco.

#### ATENÇÃO / ATTENTION / ATENCION

Nunca utilizar óleos, lustra móveis; produtos abrasivos, saponáceos, esponja de aço e outros.

Never use oils, polish furniture , abrasive products, soaps, steel sponge and others.

Nunca use aceites, pulimentos; abrasivos, jabones, esponja de acero y otros.

MONTAR O PRODUTO SOBRE A EMBALAGEM,  
EVITANDO DANOS NA PINTURA.  
ACONSELHAMOS QUE A MONTAGEM DO PRODUTO  
SEJA POR UM PROFISSIONAL.

SETUP THE PRODUCT ON TOP OF THE PACKAGING, AVOIDING  
DAMAGE TO THE PAINT.  
WE RECOMMEND THAT THE INSTALLATION IS DONE BY  
A PROFESSIONAL.

MONTAR EL PRODUCTO EN EL PAQUETE,  
EVITAR LESIONES EN PINTURA.  
AVISAMOS QUE EL MONTAJE DEL PRODUCTO  
SEA UN PROFESIONAL.



Ferramentas necessárias / Necessary tools / Herramientas Necesarias  
(não fornecidas) (not provided) (No proporcionadas)

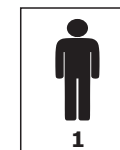

**MEDIDA UTILIZADA EM MM /  
UNIT MEASURE USED IS MILLIMETERS (MM)**

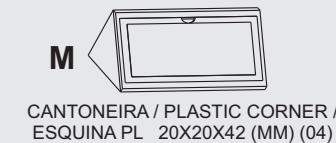
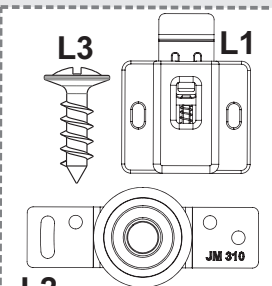
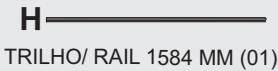
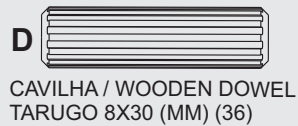
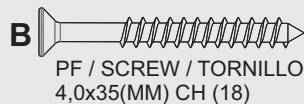

ITEM		DESCRÇÃO DA PEÇAS / DESCRIPTION OF PARTS / UNIT MEASURE USED IS MILLIMETERS (MM)	CORES / COLORS / COLORES						
CÓDIGO CODE	Nº	NOME/NAME/NOMBRE	MEDIDAS / MEASURES (MM)	TYPE	QUANT AMOUNT CANTIDAD	MEL FREIJÓ	TURQUESA	AMARELO AMARILLO YELLOW	ROSÉ ROSA
14060	01	PRATELEIRA/ SHELF/ ESTANTE	1586X381X15	MDP	01	01/18			
14061	02	DIV. SUP. ESQ./ TOP LEFT DIV.	379X165X15	MDP	01	02/18			
14062	03	DIV. SUP. DIR./ TOP RIGHT DIV.	379X165X15	MDP	01	03/18			
14063	04	DIV. INF./ LOWER DIV.	330X203X15	MDP	01	04/18			
14064	05	LAT. ESQ./ LEFT SIDE/ LADO IZQUIERDO	383X383X15	MDP	01	05/18			
14065	06	LAT. DIR./ RIGHT SIDE/ LADO DERECHO	383X383X15	MDP	01	16/18			
14066	07	BASE	1620X385X15	MDP	01	07/18			
14067	08	TAMPO/ TOP	1620X385X15	MDP	01	08/18			
14068	09	FUNDO TRÁS / BACK / TRASEIRO	534X180X03	TRI	02	09/18			
14069	10	FUNDO TRÁS / BACK / TRASEIRO	534X180X03	TRI	01	10/18			
14070	11	FUNDO TRÁS / BACK / TRASEIRO	803X225X03	TRI	02	11/18			
14071	12	REFOR. PÉ/ FOOT REINFORCEMENT/ REFUERZO PIE	1250X80X25	MDF	02	12/18			
14072	13	FRENTE GAV. ESQ./ DRAWER FRONT RIGHT / FRENTE DE CAJÓN IZQ.	514X158X15	MDF	01	13/18		13/23	
14073	14	FRENTE GAV. DIR./ DRAWER FRONT LEFT / FRENTE DE CAJÓN DER.	514X158X15	MDF	01				14/35
14074	15	LAT.GAV.ESQ.DIR/LEFT/RIGHT DRAW. SIDE/LADO CAJÓN IZQ.DER.	350X115X15	MDP	04	15/18			
14075	16	CONT. FRENTE. GAV./AGAINST DRAWER FRONT/ CONTRA EL FRENTE DEL CAJÓN	463X115X15	MDP	02	16/18			
14076	17	FUNDO GAV. / DRAWER BACKGROUND/ FONDO CAJÓN	491X358X15	TRI	02	17/18			
14077	18	PORTA CORRER/ SLIDING DOOR/ PUERTA CORREDIZA	820X195X15	MDF	01		18/21		
438	A	PF. / Screw / Tornillo 4,0x40(MM) CH			18				
437	B	PF. / Screw / Tornillo 4,0x35(MM)			18				
986	C	PF. / Screw / Tornillo 3,5x14(MM) CRR			48				
137	D	Cavilha / Wooden Dowel / Tarugo 8x30(MM)			36				
532	E	Pino Minifix / Minifix Screw 32(MM)			14				
508	F	Tambor Minifix / Minifix Round Nut 15(MM)			14				
13879	G	Tapa furo adesivo freijó 15 MM			10	FREIJÓ			
14419	H	Trilho PL. / Rail Plastic PL 1584(MM)			01	CAFÉ			
248	I	Prego / Nail / Clavo 8x8(MM)			50				
911	J	Garra/ Jont Metal Plate/ Embragues			11				
139	K	Corred./Metallic Slid 350(MM) (02 PAIR)			02				
9002	L	Kit porta de correr/ Sliding Door Kit			01				
15175	M	Cantoneira PL/Plast. corner with lid / Esquina PL. 20X20X42(MM)			04	CINZA			
10203	N	Pé Palito Mad. c/ haste/ Wooden Leg 170 (MM) wiht stem/ Pies Pallilo Madera c/varilla			04	MEL			
3441	O	Amortecedor/ Pu Bumper/ Parachoques			04				
15203	P	Porca Garra de aço/ Steel Claw Nut/ Tuerca de Garra de Acero			04				
		Certif. de Garant. / Warranty Certif.			01				

**FIXAR PINO DE MINIFIX, TAMBOR E TAMPA / FIXING THE MINIFIX PIN, DRUM AND MINIFIX COVER  
COLOQUE EL PINO E TAMBOR MINIFIX Y LA TAMPA**

**PREPARAÇÃO DE PEÇAS/ PARTS PREPARATION / PREPARACION DE PIEZAS**

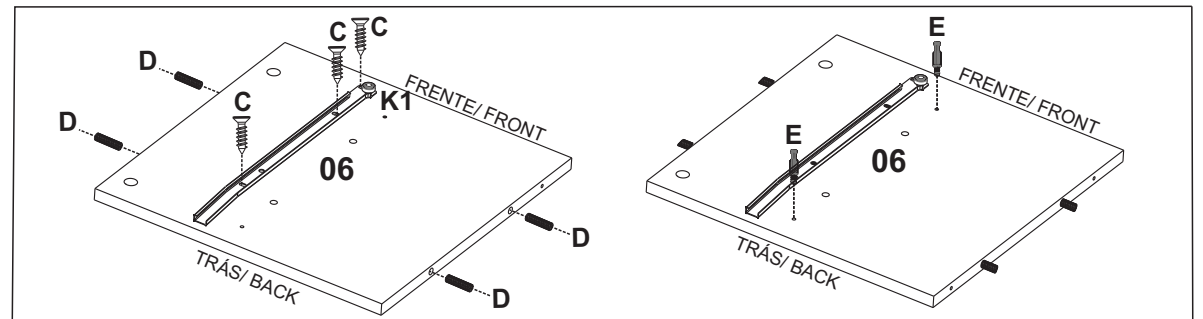
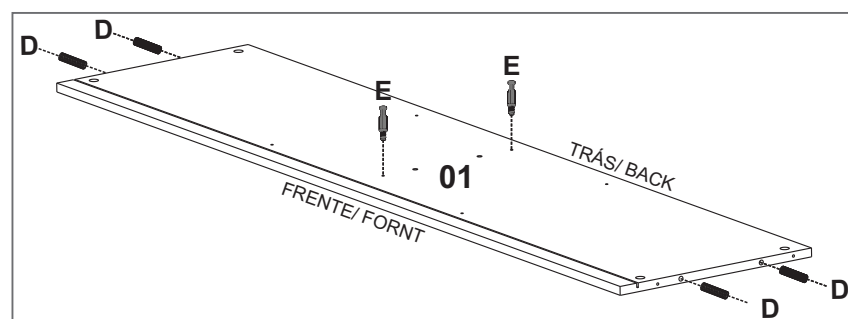
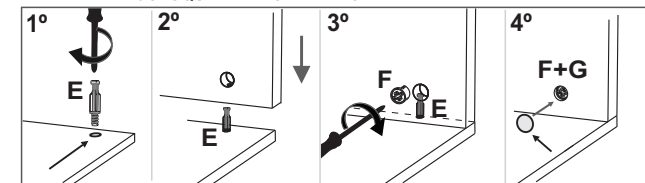
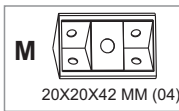
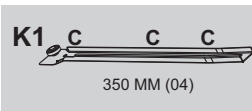
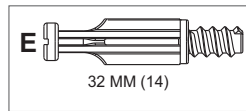
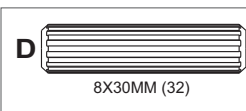
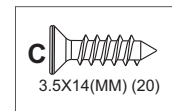

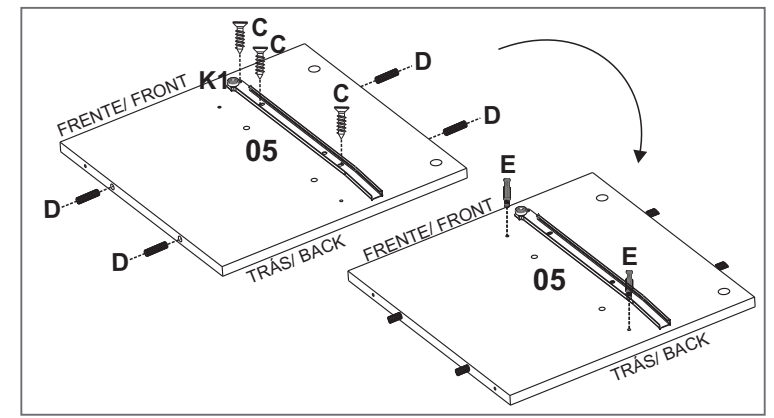
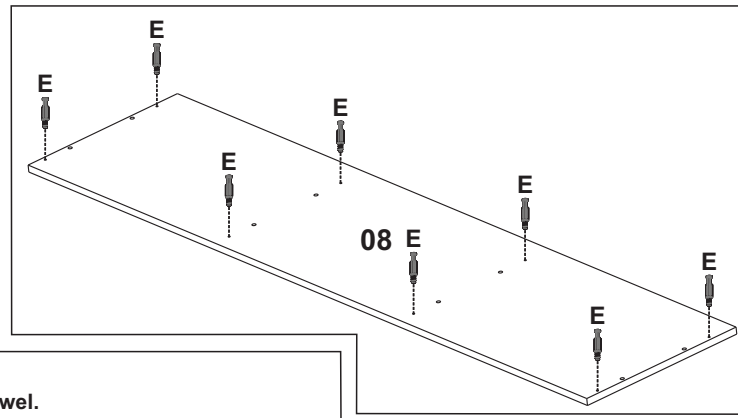
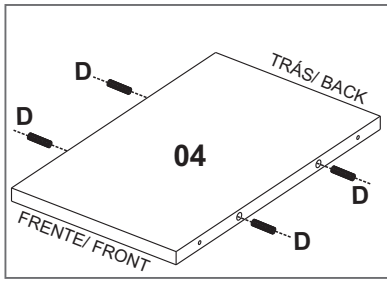

Parafusar as cantoneiras entre as cavilhas.  
Screw the plastic corner between the wooden dowel.  
Atornillar las esquinas entre las tarugos.

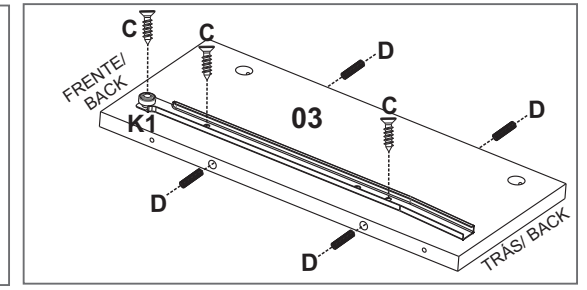
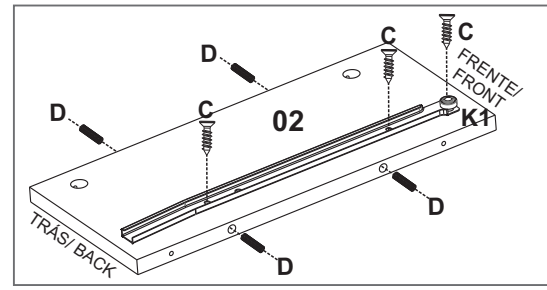
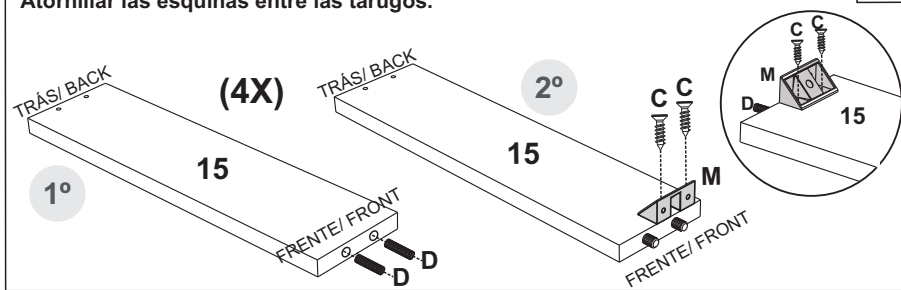

**1** Obs: As cores apresentadas nos passos são meramente ilustrativas.  
The colors presented in the steps are merely illustrative.  
Los colores que se muestran en los pasos son simplemente ilustrativos.

**ATENÇÃO/ ATTENTION / ATENCIÓN**

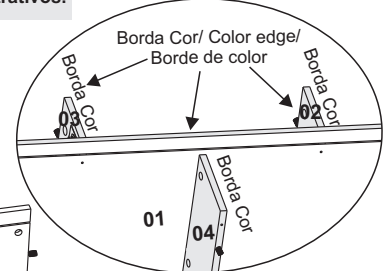
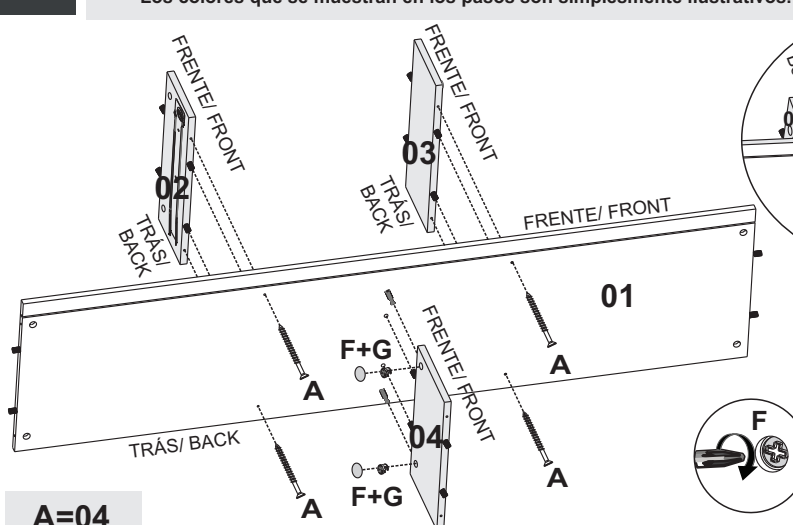

**A=04**  
**F=02**  
**G=02**

**2**

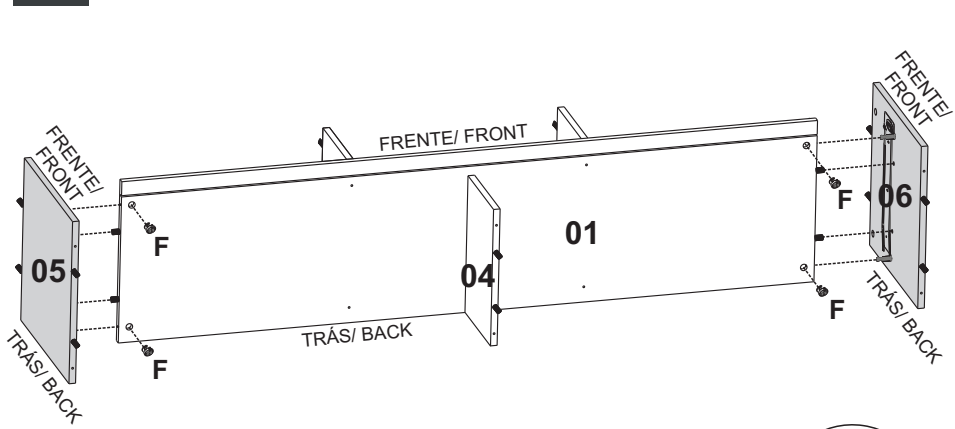

**F=04**

3

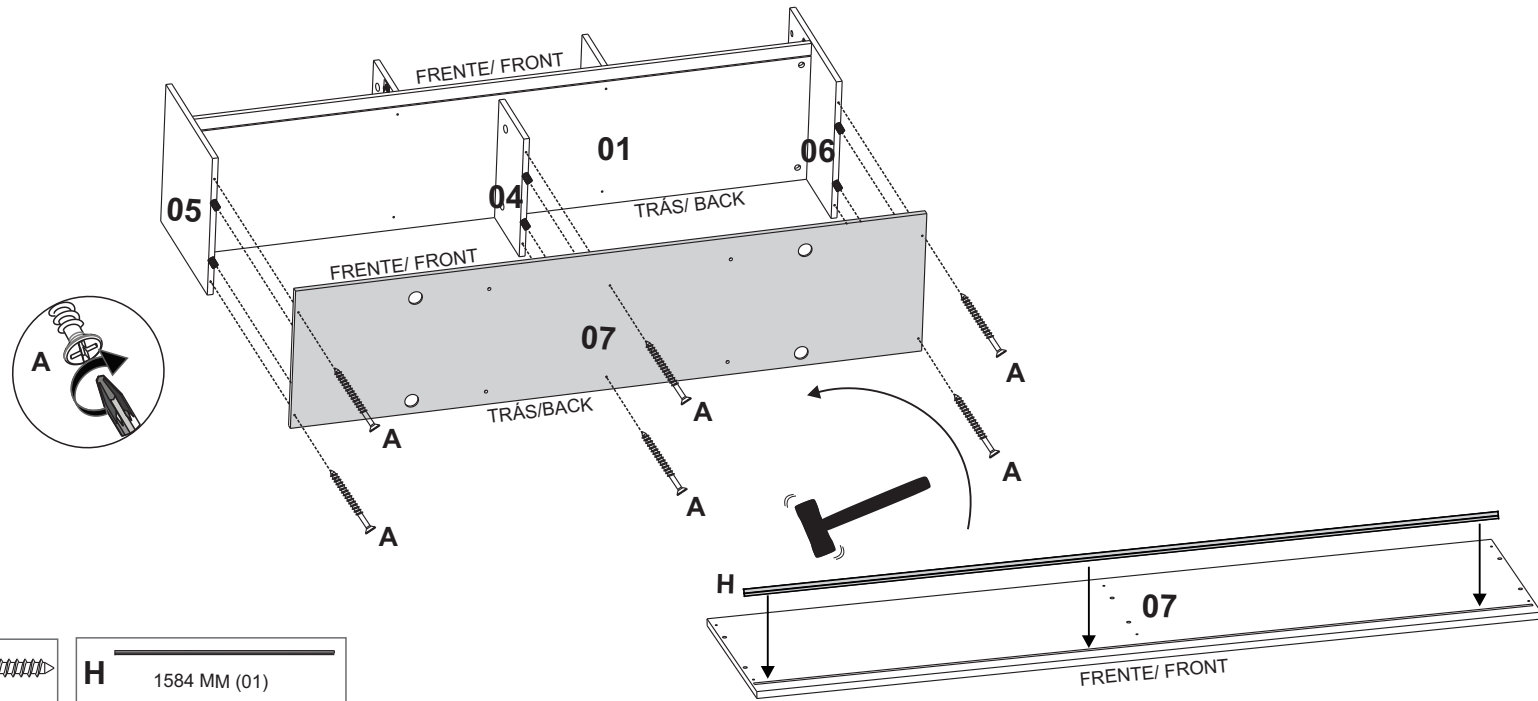

A=06  
H=01

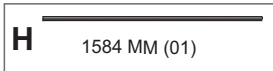
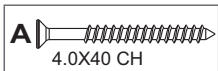

4

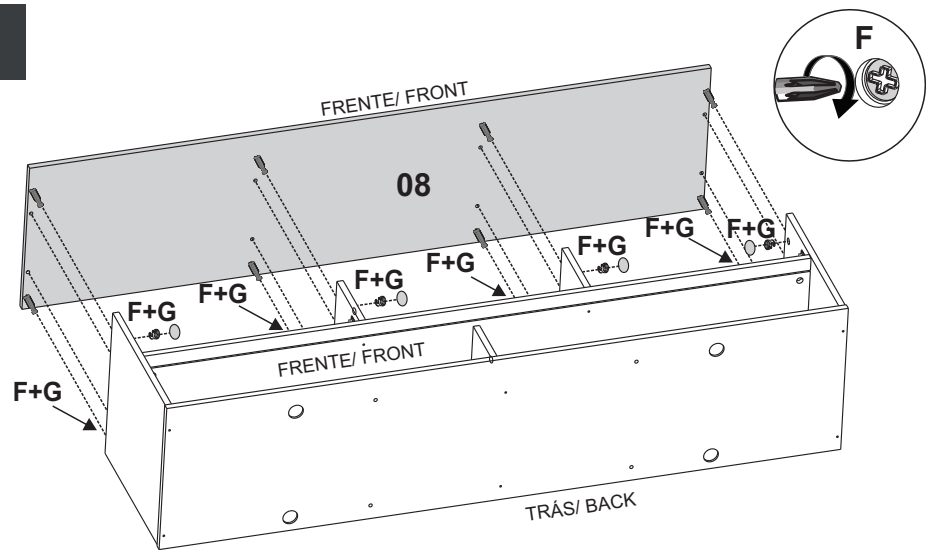

F=08  
G=08

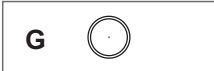

5

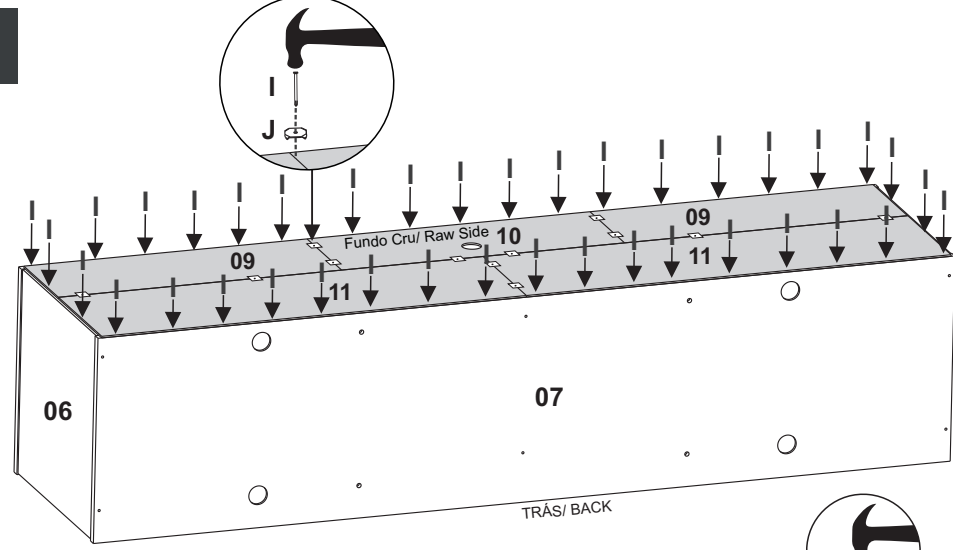

I=50  
J=11

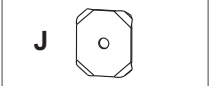

6

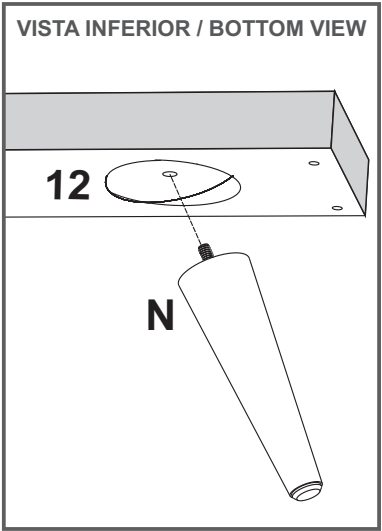

! FIXAÇÃO PÉS/ LEG FIXATION/ FIXACION PIES

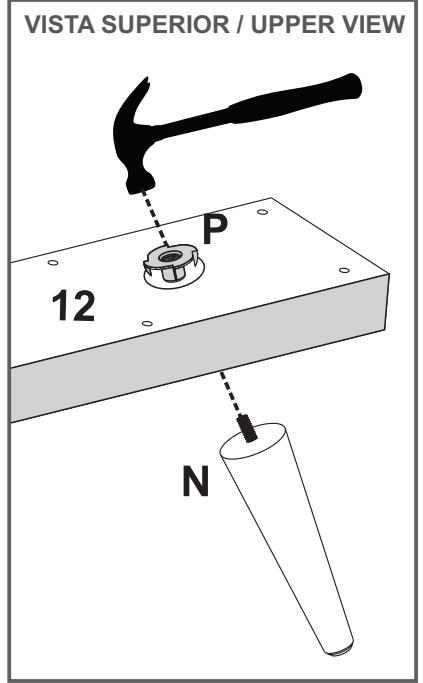
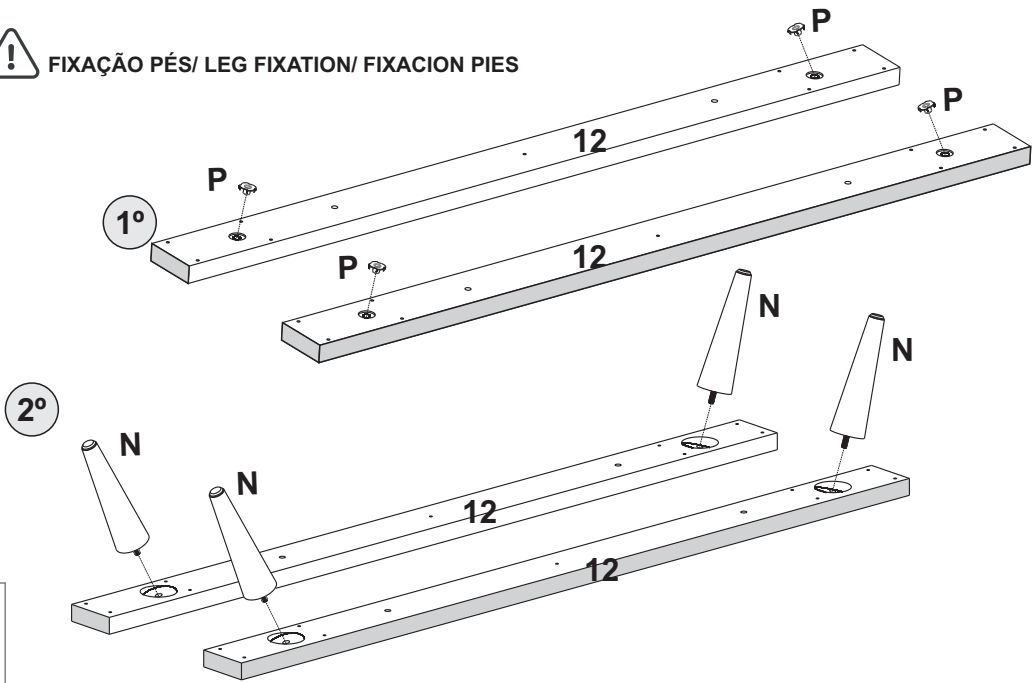

N=04  
P=04

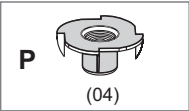
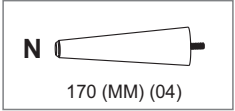

7

ATENÇÃO/ ATTENTION / ATENCION

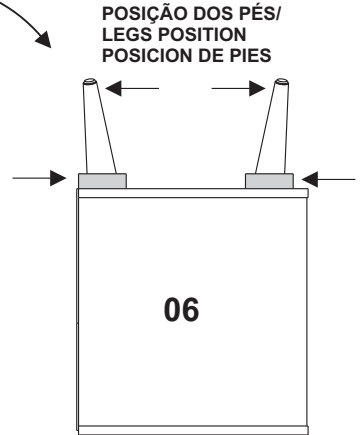
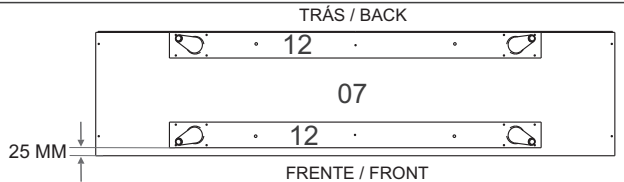
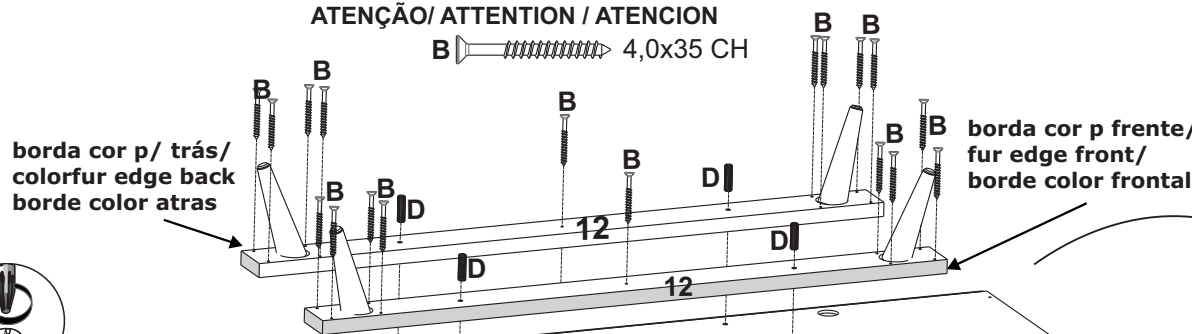

B=22  
D=04

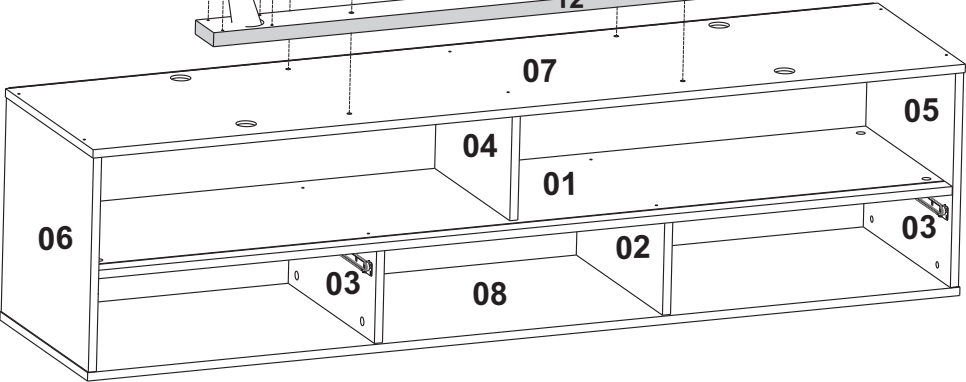
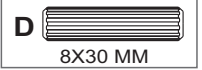
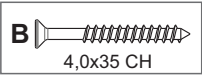

# 8 MONTAGEM GAVETA / ASSEMBLY OF THE DRAWER / MONTAJE LE CÁJON

**1º**

**2º**

**3º**

**4º**

**5º**

**A=08**  
**C=28**  
**K2=04**  
**M=04**

**A** 4.0X40 CH    **C** 3,5X14 CRR    **K2** 350MM    **M**

## 9

**ATENÇÃO/ ATTENTION / ATENCION**

REGULAR O PARAFUSO/ SCREWADJUSTMENT/ AJUSTE EL TORNILLO

ABAIXAR E ENCAIXAR/ LOWER THE DEVICE/ FOR IT TO FIT IN ABAJAR E AJUSTAR

**L1=02**  
**L2=02**  
**L3=08**  
**O=04**

**FIXAÇÃO**

**L3** **L1**  
**L2**

**O**

**GUIA SUP./ TOP GUID**

**GUIA INF./ LOWER GUID**

**SUPERIOR / HIGHER**

**INFERIOR / BOTTOM**

**25 MM (SUPERIOR/HIGHER)**

**10 MM (INFERIOR/BOTTOM)**

**COLOCAR "O" NA PEÇA 18**  
**PUT "O" IN PART 18**  
**PONER "O" LA PIEZA 18**

**ENCAIXAR / TO FIT IN**