

Linea Brasil

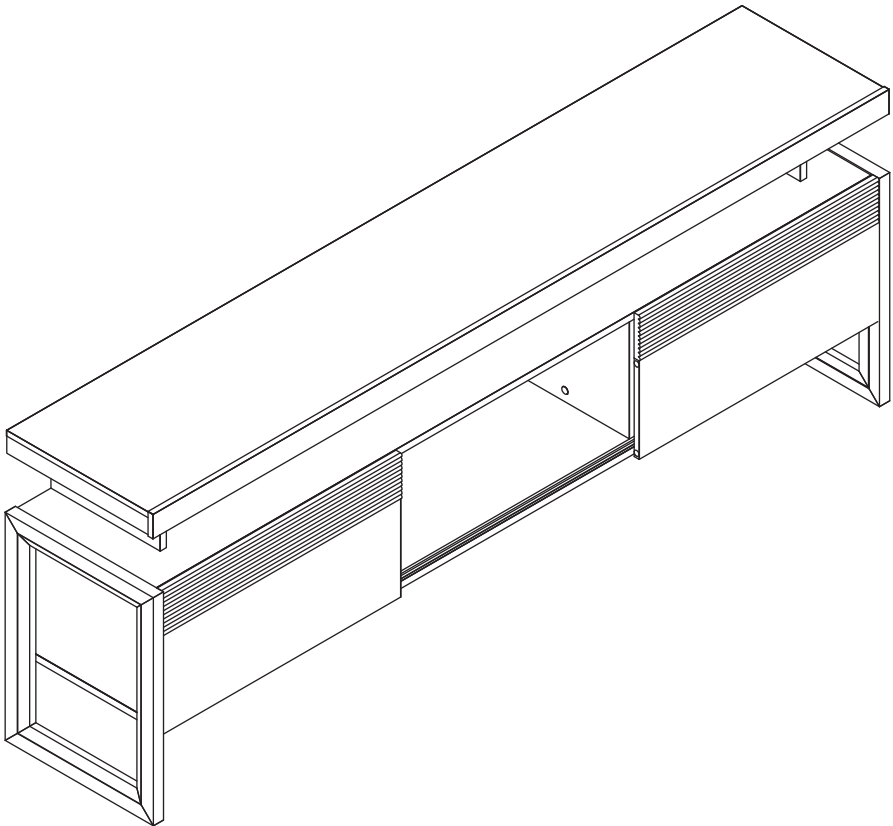

RACK ESMERALDA

V-2 17/08/23

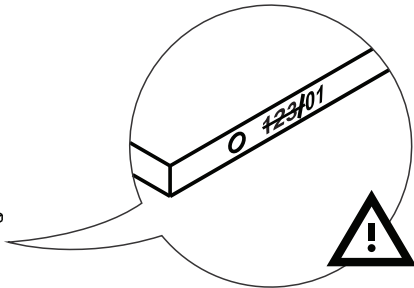
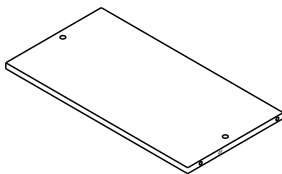
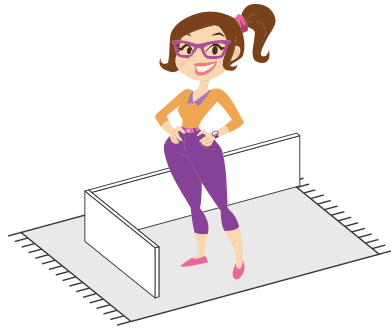
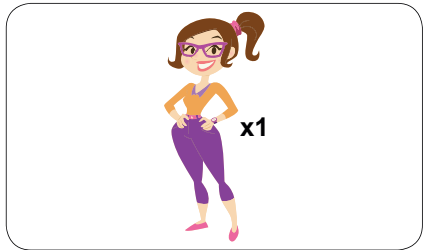
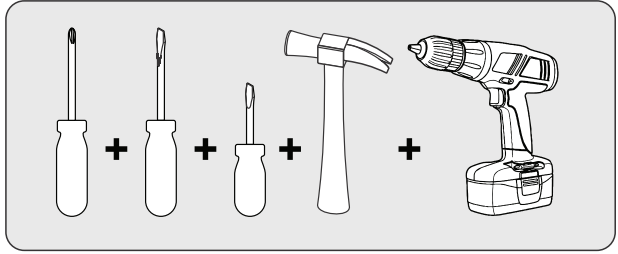
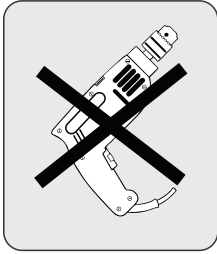

GARANTIA / Warranty / Garantía

Nossos produtos são garantidos por 90 dias contra defeitos de fabricação. Ao constatar um problema coberto pela garantia, entre em contato com a loja onde o produto foi comprado. Ela estará capacitada para atendê-lo da melhor forma diante de cada caso. Reclamações de garantia somente poderão ser atendidas se o termo de garantia for apresentado no ato de reivindicação, acompanhado de sua nota fiscal de compra.

Nuestros productos están garantidos contra defectos de fabricación por 90 días, a partir de la compra. Ao constatar un problema protegido por la garantía, póngase en contacto con la tienda donde se adquirió el producto. Ella estará capacitada para atenderlo de la mejor manera de acuerdo con cada caso.

Our products are guaranteed against manufacturing defects for 90 days from the date of purchase. When you find a problem covered by the warranty, please contact the store where the product was purchased. The store will be able to serve you in the best way in each case.

Exclusões

- Desgaste natural ou danos causados por água, maresia, ferrugem, incêndio, calor, cupins e pragas em geral
- Montagem, manutenção e uso inadequado
- Não cumprimento das recomendações técnicas do esquema
- Montagens e desmontagens após a primeira instalação
- Instalações elétricas e outras afins

Exclusiones

- Desgaste natural o daños causados por agua, maresia, incendios, calor, termitas y plagas en general
- Montaje, mantenimiento y uso inadecuado
- No cumplimiento de las recomendaciones técnicas del esquema
- Montaje y desmontaje después de la primera instalación
- Instalaciones eléctricas y otras afines

Exclusions

- Natural wear or damage caused by water, sea, rust, fire, heat, termites and plagues in general
- Assembly, maintenance and improper use
- Failure to comply with the technical recommendations of the assembly instructions
- Assembly and disassembly after first installation

Importante

A Linha Brasil não autoriza nenhuma pessoa, loja ou entidade assumir em seu nome qualquer outra garantia que não conste no certificado. O fabricante reserva-se no direito de efetuar nos produtos eventuais modificações que considerar necessárias, sem prejudicar as características essenciais. Os produtos terão peças de assistência para reposição no período de 1 ano a contar de sua retirada do mercado, desde que haja matéria-prima equivalente, observando o dispositivo no Art.32 da Lei 8.078/90 (Cód. Defesa do Consumidor). O atendimento para produtos fora de linha é feito por programação especial, através da loja revendedora sob aprovação de consulta prévia ao fabricante.

Importante / Línea Brasil no autoriza a ninguna persona, tienda o entidad a asumir en su nombre cualquier otra garantía que no figure en el certificado. El fabricante se reserva el derecho de efectuar en los productos eventuales modificaciones que considere necesarias, sin perjudicar las características esenciales. Los productos tendrán piezas de asistencia para reposición en el período de 1 año a partir de su retirada del mercado. La atención para productos fuera de línea es hecha por programación especial, a través de la tienda revendedora bajo aprobación de consulta previa al fabricante.

Important / Línea Brasil does not authorize any person, store or entity to assume on its behalf any other warranty that does not appear on the certificate. The manufacturer reserves the right to make in the products any modifications that it considers necessary without prejudice to the essential characteristics. The products will have replacement parts within one year of being withdrawn from the market. The service for off-line products is done by special programming, through the store reseller under prior consultation with the manufacturer.

INSTRUÇÕES DE LIMPEZA E CONSERVAÇÃO

CLEAN AND PRESERVATION INSTRUCTURE / INSTRUCCIONES PARA LA LIMPIEZA Y CONSERVACION

Para retirar pó, utilize um pano seco, espanador ou aspirador. Se necessário para uma limpeza mais efetiva, utilize um pano levemente úmido com água. Finalize com uma flanela limpa e seca.

To take dirt, use a dry cloth, duster or vacuum. If necessary to take the dust, use a wet cloth. Finish with a clean and dry flannel.

Para eliminar el polvo, utilice un paño seco, mopa o la aspiradora. Si es necesario para una limpieza más eficaz, con paño ligeramente humedecido con agua. Terminar con un paño limpio y seco.



! IMPORTANTE / IMPORTANT / IMPORTANTE



Não utilize produtos abrasivos como álcool e detergentes, como também esponjas rígidas ou palhas de aço na limpeza dos móveis.

Do not use abrasives such as alcohol and detergent, tough soaker also steel wool to clean the furniture.

No use limpiadores abrasivos como alcohol e detergentes, así como esponjas rígidas o lana de acero para limpiar los muebles.



Proteja a superfície do móvel de objetos que transmitam calor ou umidade.

Protect the surface of the furniture against objects that can pass heat and humidity.

Proteja la superficie del mueble de objetos que transmitan calor o humedad.



Evitar o contato de água e produto de limpeza com o rodapé do produto, pois poderá danificá-lo.

Avoid the contact of water and cleaning products with baseboard, cause it should damage your product.

Evitar el contacto con agua y producto de limpieza con el rodapié del producto, pues podrá dañar.



Procure sempre utilizar flanela limpa e seca para limpeza.

Try always to use a clean and dry flannel to cleaning.

Busque siempre utilizar franela limpia y seca para la limpieza.

Cuidado com objetos pontiagudos, eles podem arranhar a superfície das portas e tampo.

Take care with sharp objects, they can scratch the door lid surface.

Cuidado con objetos afilados, ellos pueden rayar la superficie de las puertas y la tapa.

Imagem Ilustrativa/ Illustrative Image/ Imagen Ilustrativa

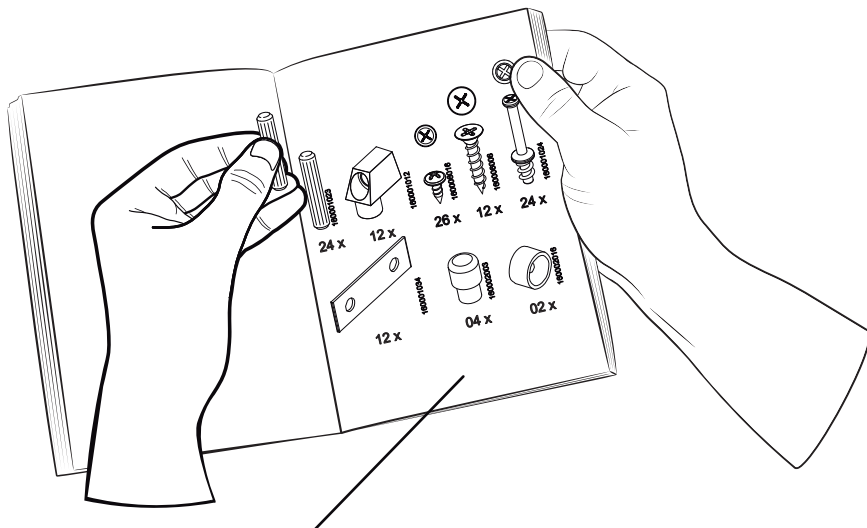

Preste Atenção! ¡Preste atención! Attention!



As ferragens dos nossos manuais são sempre apresentadas nas mesmas proporções da peça na vida real.
Caso apareça alguma dúvida no decorrer do processo de montagem, coloque a ferragem ao lado do desenho e faça a consulta :D

Los accesorios de nuestros manuales siempre se presentan en las mismas proporciones que la pieza en la vida real.
Si tiene alguna duda durante el proceso de montaje, coloque los accesorios junto al dibujo y haga una consulta :D

The accessories in our manuals are always presented in the same proportions as the spare part in real life.
If you have any questions during the assembly process, place the accessory next to the drawing and make an inquiry :D

Símbolos: Símbolos: Symbols:



- + Parafuso Phillips
- Parafuso Fenda
- Parafuso Allen

- + Tomillo Phillips
- Tomillo Ranurado
- Tomillo Allen

- + Phillips screw
- Slotted Screw
- Allenscrew

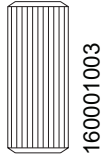

04x

160001003

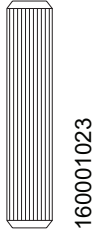

28x

160001023

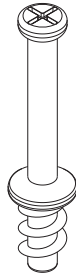

19x

160001024

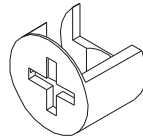

19x

160001025



50x

160006011

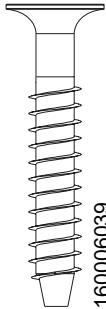

02x

160006039

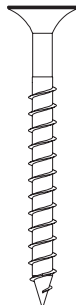

03x

160006006



12x

160006018



66x

160006016

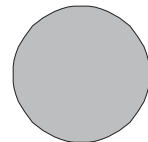

30x

160002002



08x

160002015



160001011

05x

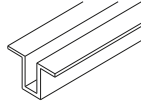

160012024

02x

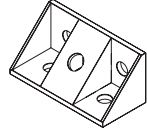

160001018

10x

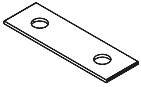

160001034

08x

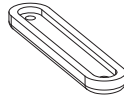

160002004

06x



160002012

02x

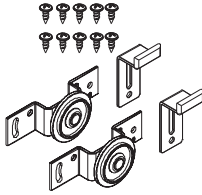

160003005

04x

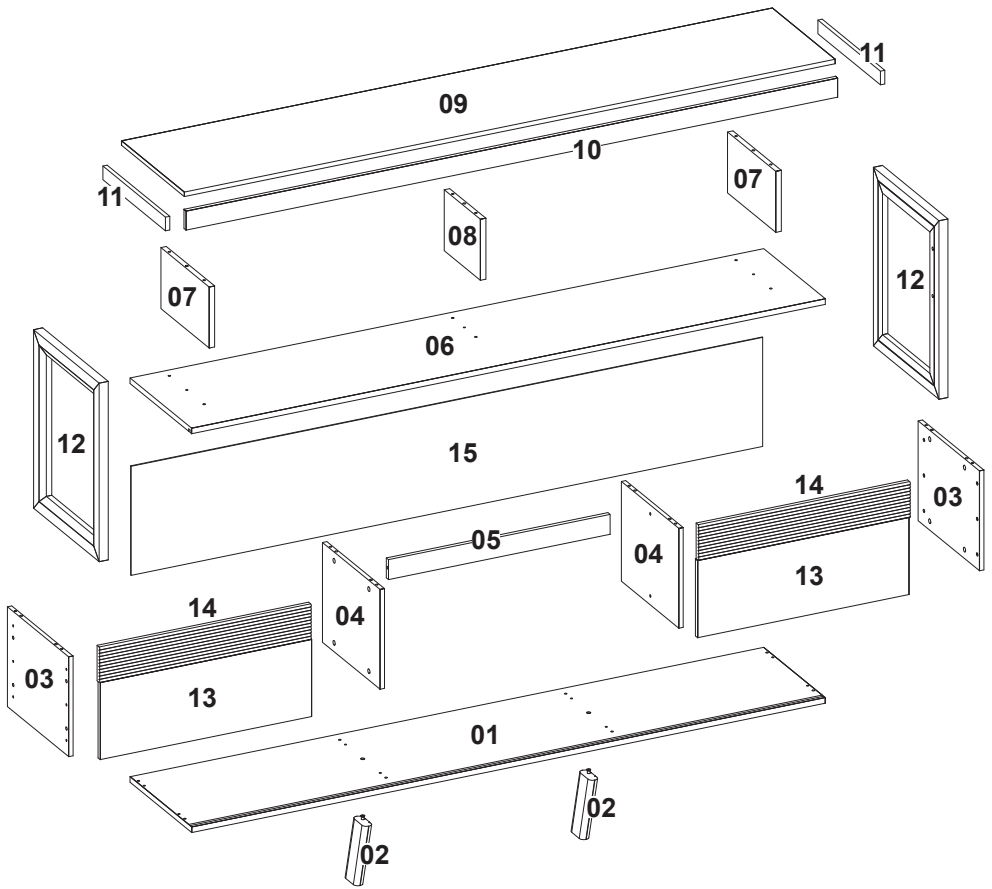

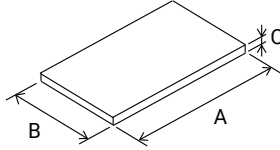

VOLUMEN Caja Box	ITEM Artículo Item	PEÇA Peza Part	DESCRICOÃO Descripción Description	DIMENSOES (mm) Dimensión/Dimension			QUANTIDADE La cantidad The amount	MATERIAL
				A	B	C		
1	1	510305001	BASE	1750	340	15	1	MDP
1	2	510305002	PE CENTRAL	180	65	25	2	MDF
1	3	510305003	LATERAL	339	270	12	2	MDP
1	4	510305004	DIVISAO	318	270	12	2	MDP
1	5	510305005	TRAVESSA TAMPO INFERIOR	612	60	12	1	MDP
1	6	510305006	TAMPO INFERIOR	1750	340	15	1	MDP
1	7	510305007	DIVISAO DVD LATERAL	267	166	15	2	MDP
1	8	510305008	DIVISAO DVD CENTRAL	200	166	15	1	MDP
1	9	510305009	TAMPO SUPERIOR	1798	347	12	1	MDP
1	10	510305010	ENCABECAMENTO TAMPO	1800	52	12	1	MDP
1	11	510305011	VISTA LATERAL DO TAMPO	347	37	12	2	MDP
1	12	510305012	PES	483	362	25	2	MDF
1	13	510305013	PORTA	584	209	12	2	MDP
1	14	510305014	MOLDURA PORTA	584	298	15	2	MDF
1	15	510305015	FUNDO	1744	298	2,8	1	MDF

ARTICULO	DESCRIPCION
1	BASE
2	PATA CENTRAL
3	LATERAL
4	DIVISION
5	TRAVESAÑO BASE TV INFERIOR
6	BASE TV INFERIOR
7	DIVISION DVD LATERAL
8	DIVISION DVD CENTRAL
9	BASE TV SPERIOR
10	ENCABEZAMIENTO BASE TV
11	ENCABEZAMIENTO LATERAL BASE TV
12	PATAS
13	PUERTA
14	MARCO PUERTA
15	FONDO

ITEM	DESCRIPTION
1	BASE
2	CENTRAL FOOT
3	LATERAL
4	DIVISION
5	LOWER TV BASE CROSSBAR
6	LOWER TV BASE
7	SIDE DIVISION DVD
8	CENTRAL DIVISION DVD
9	UPPER TV BASE
10	TV BASEBOARD FRAME
11	TV BASEBOARD LATERAL FRAME
12	FEET
13	DOOR
14	DOOR FRAME
15	BACK PANEL

1

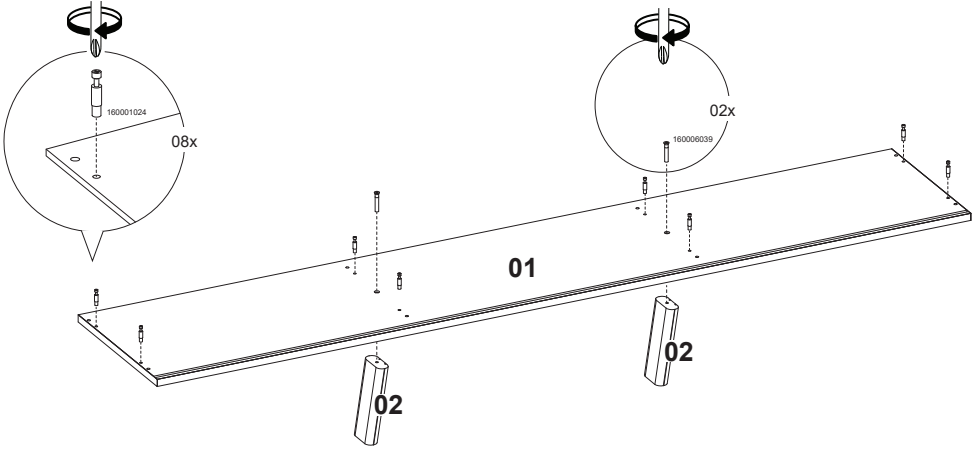
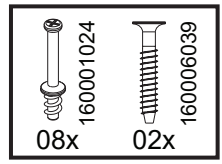
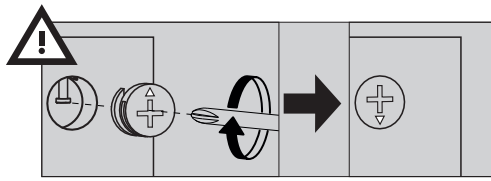

2

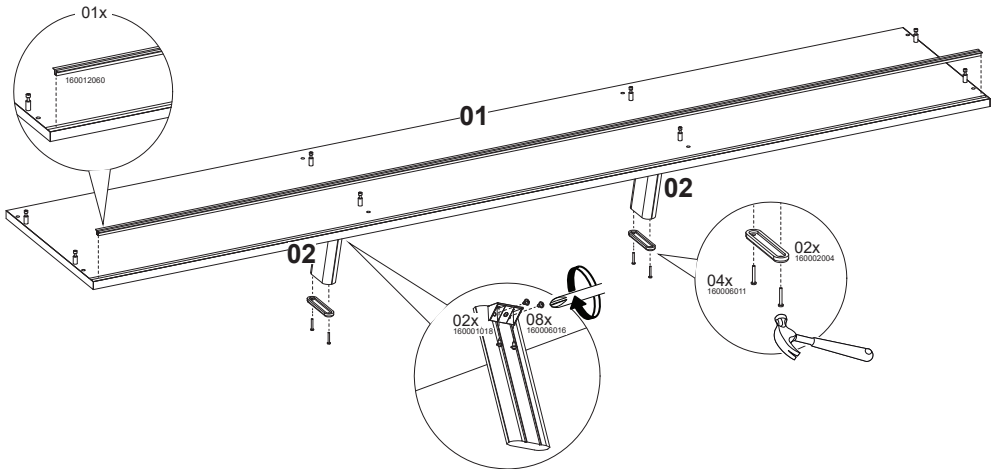
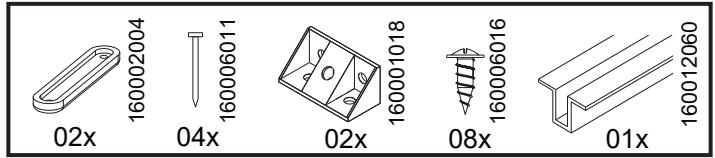

3

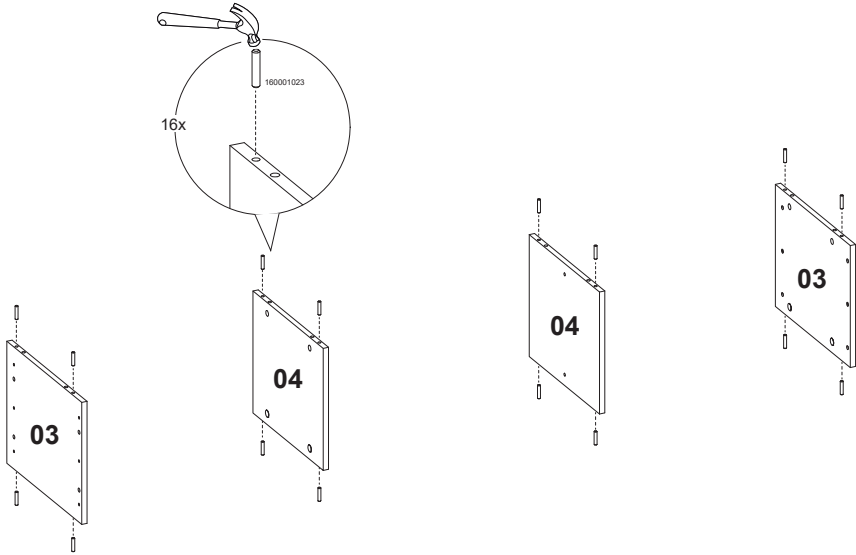
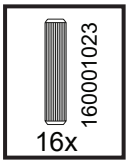

4

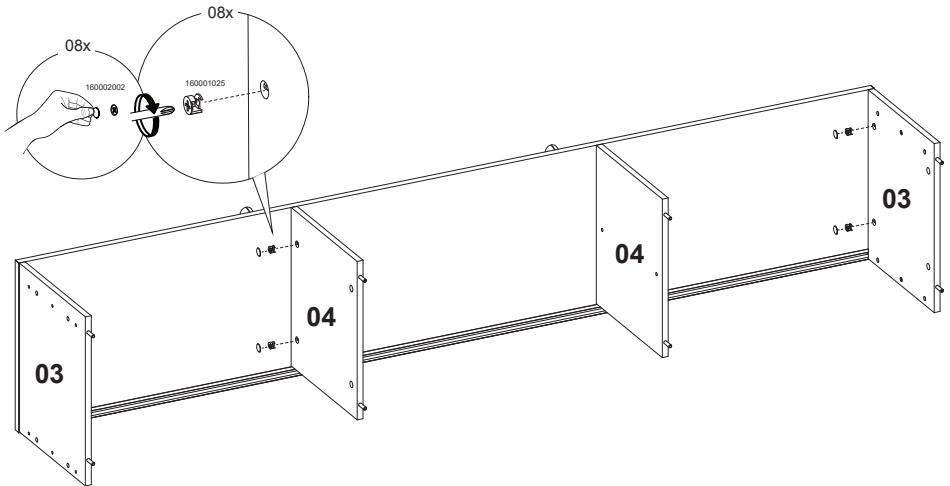
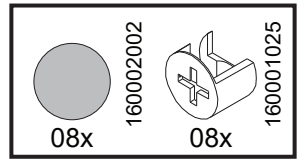
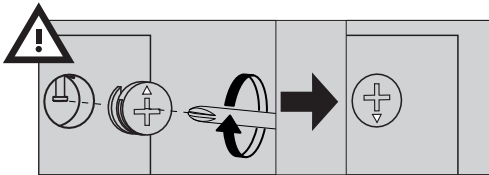

5

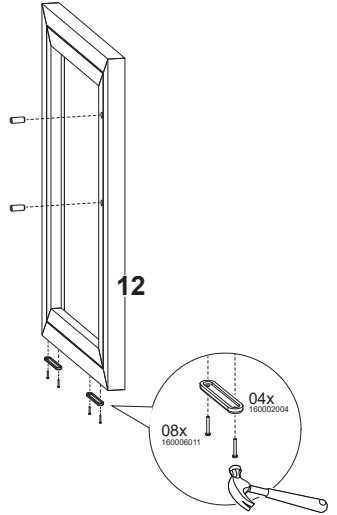
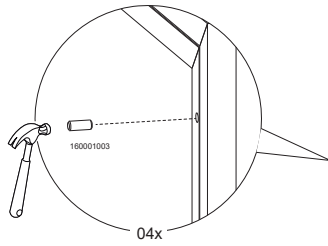
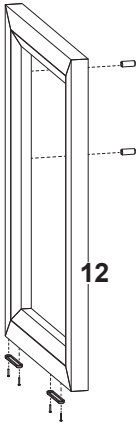
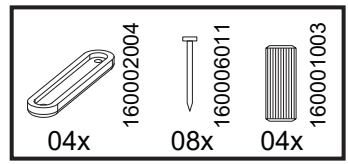

6

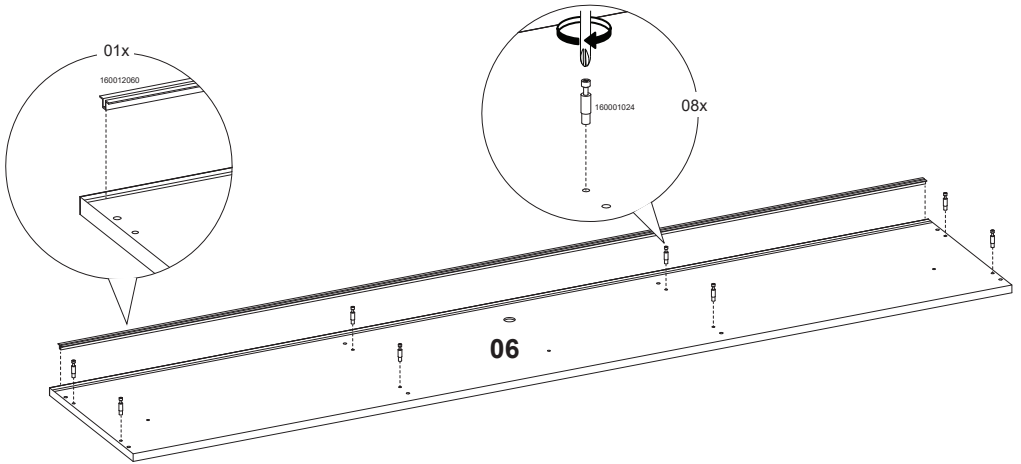
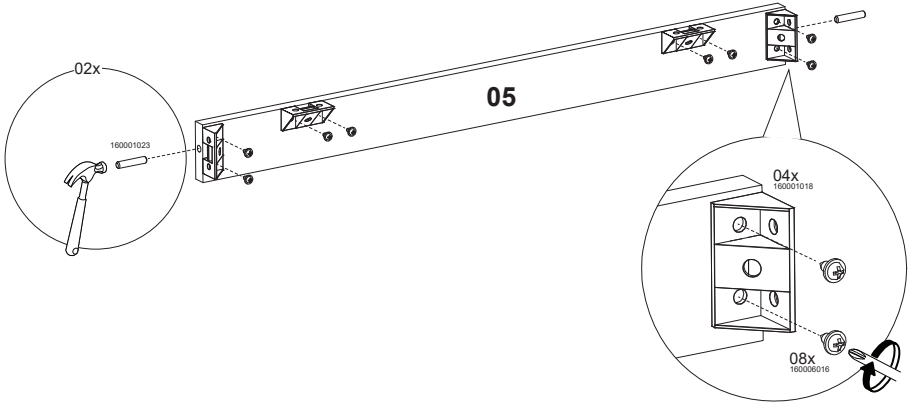
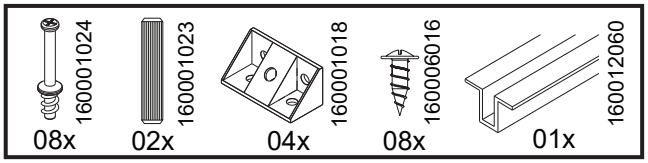

7

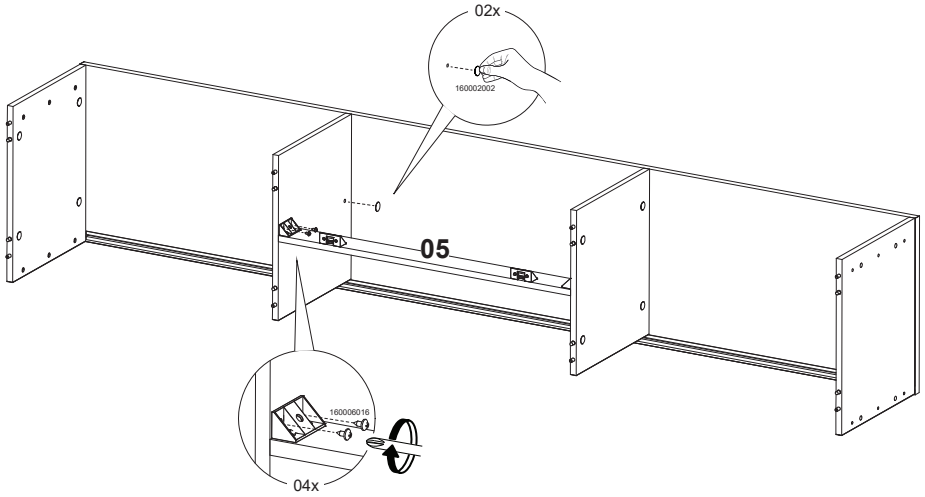
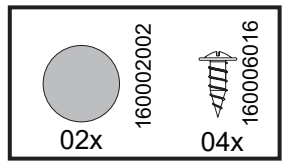

8

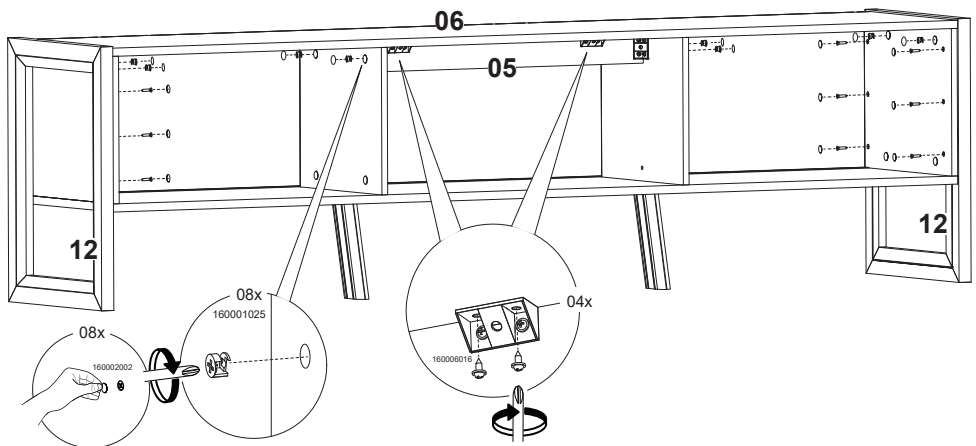
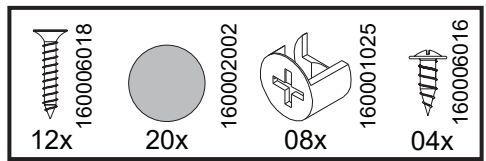
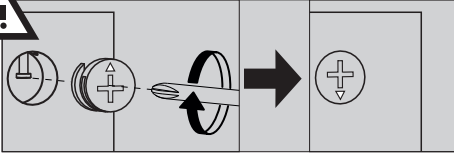

9

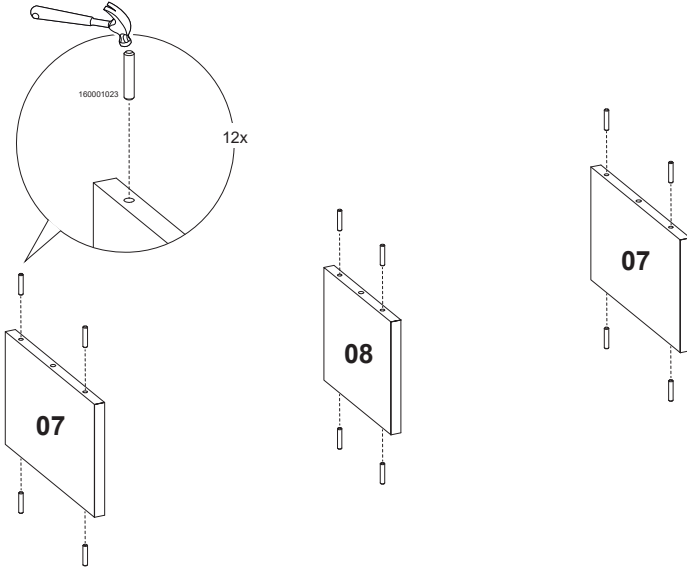
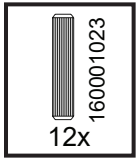

10

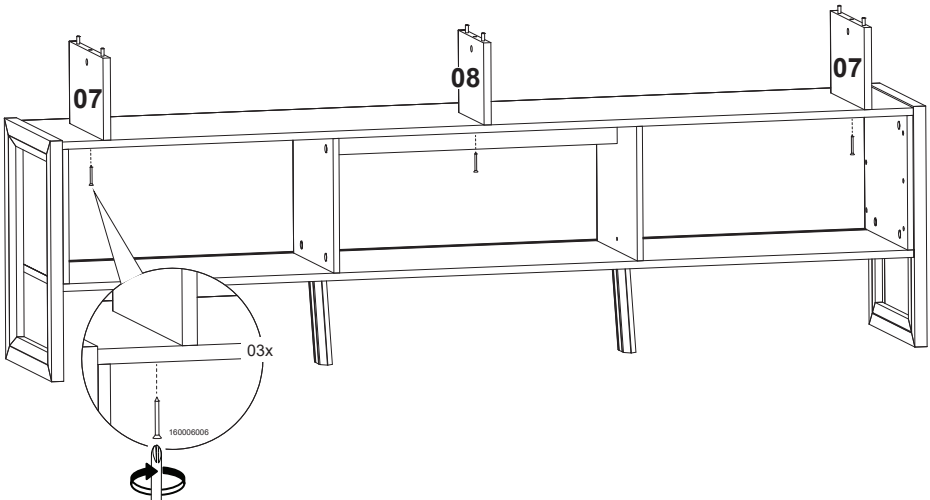
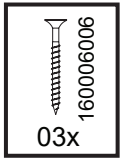

11

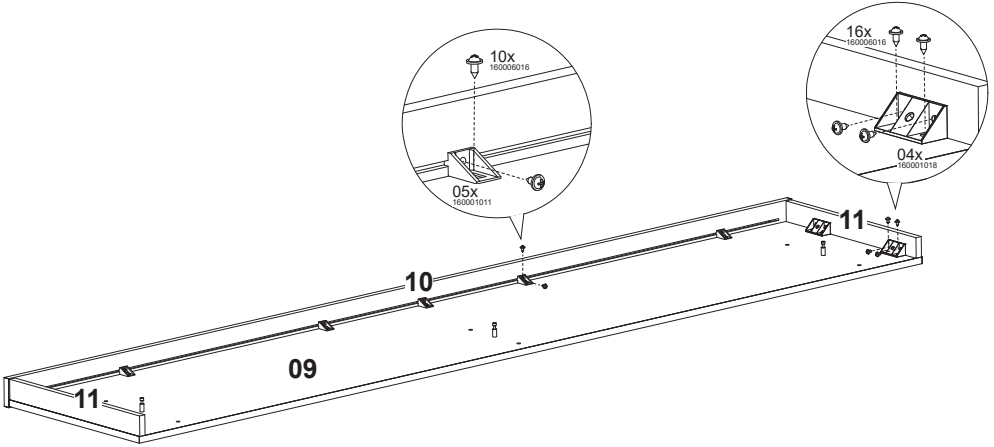
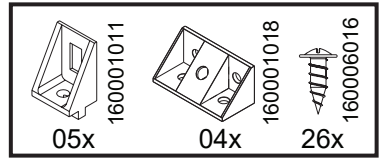

12

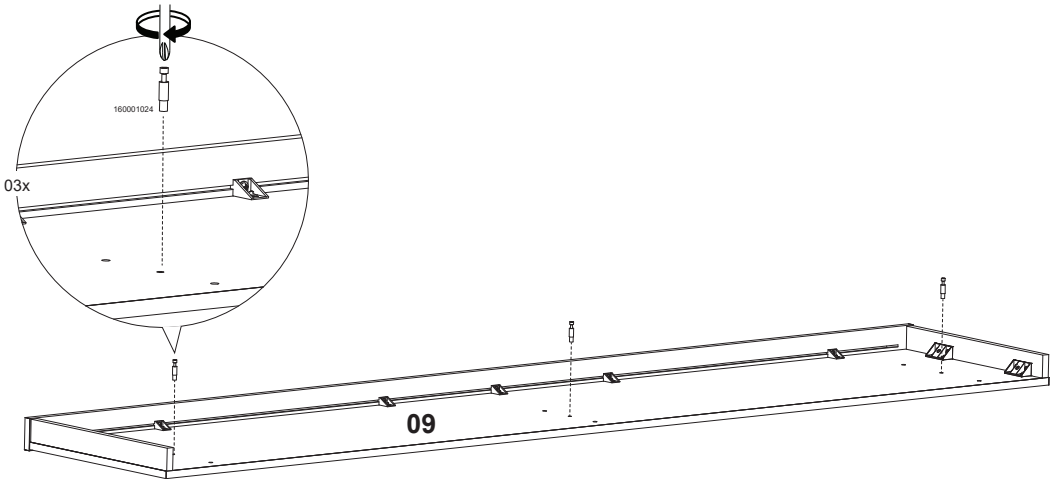
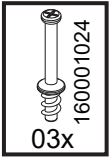

13

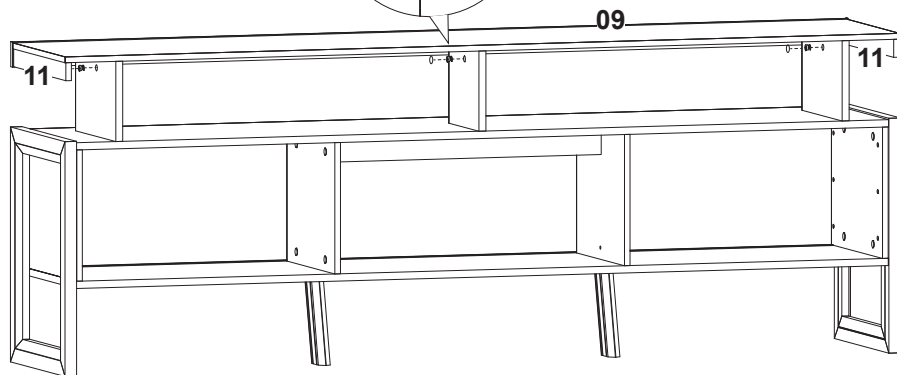
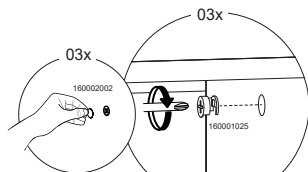
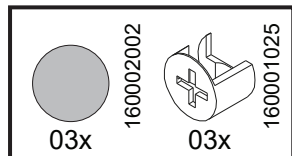
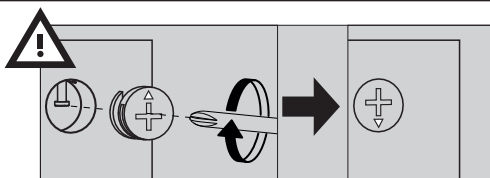

14

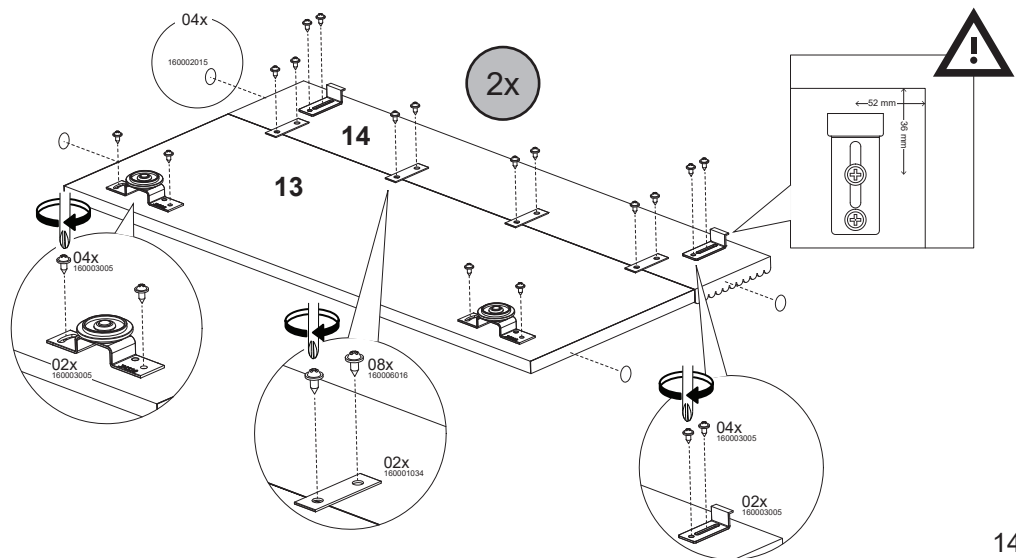
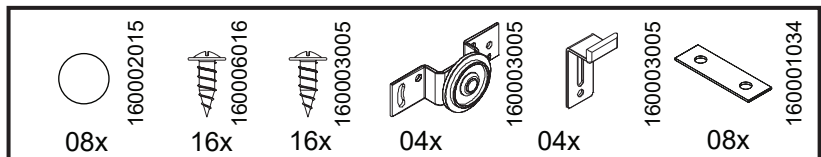

15

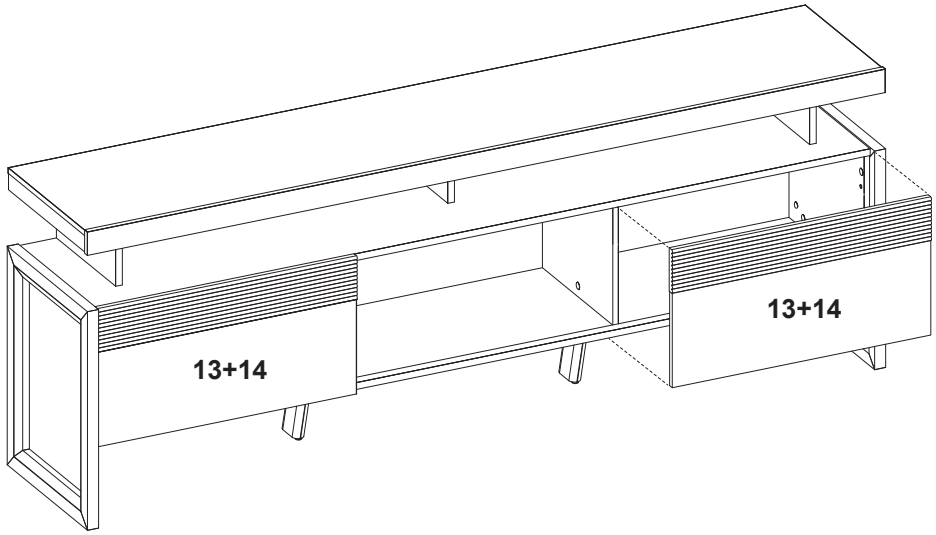

16

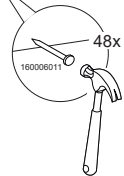
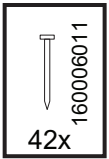
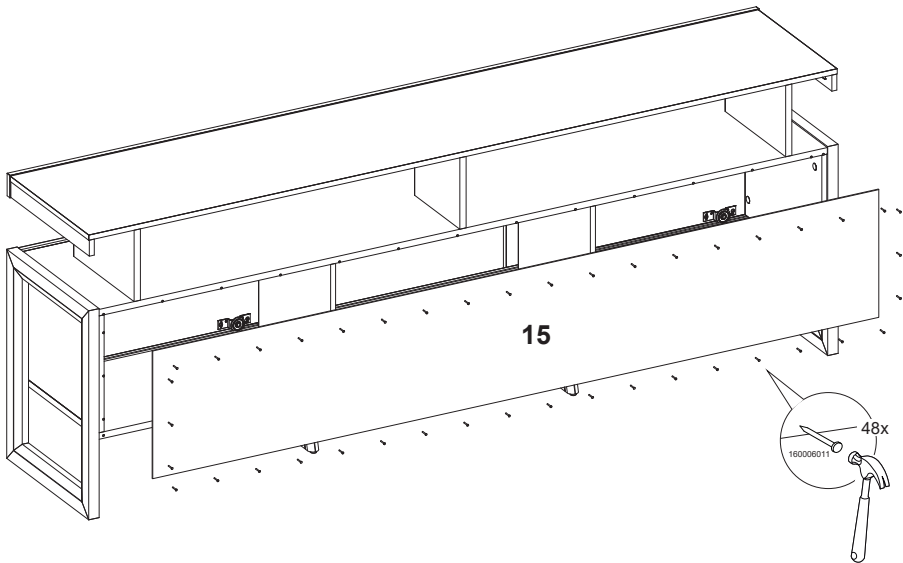

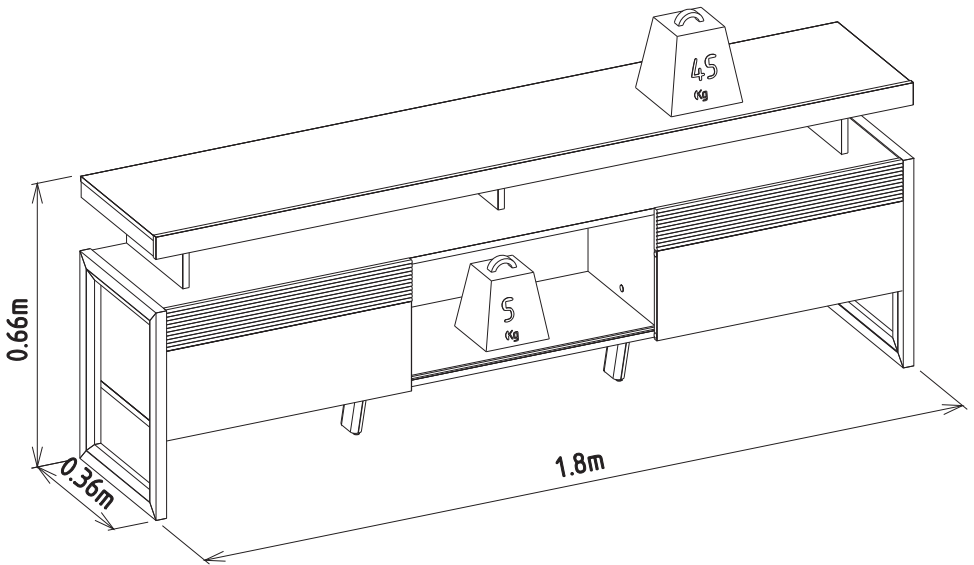

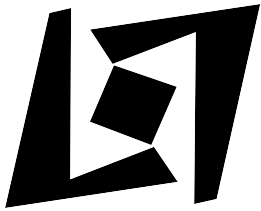

Linea Brasil