

CO7310 - TORRE QUENTE 0,7 M

Manual de Montagem
 Assembly Instructions
 Instrucción de Montaje

decibal[®]
 móveis

Produto Montado
 Producto final
 Assembled

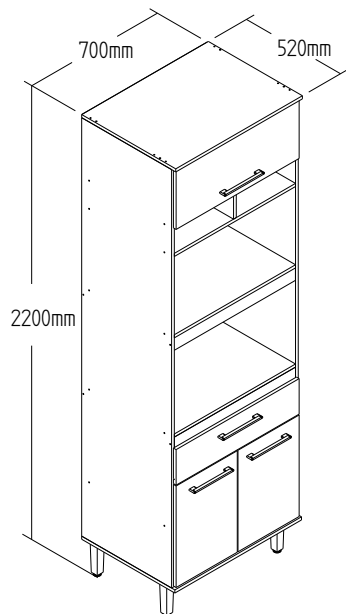

01°

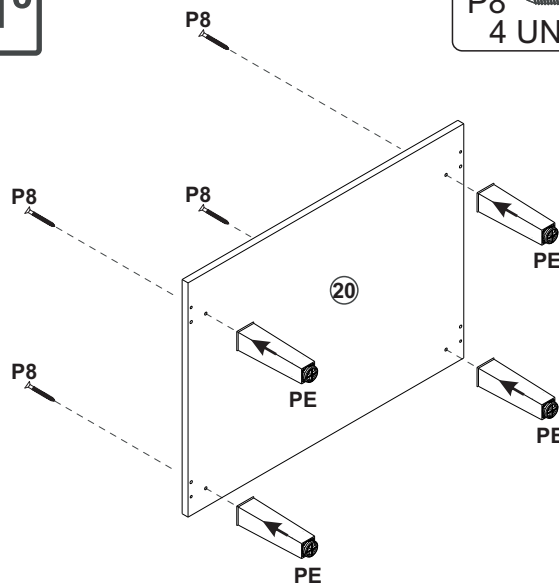

P8
 4 UNI

02°

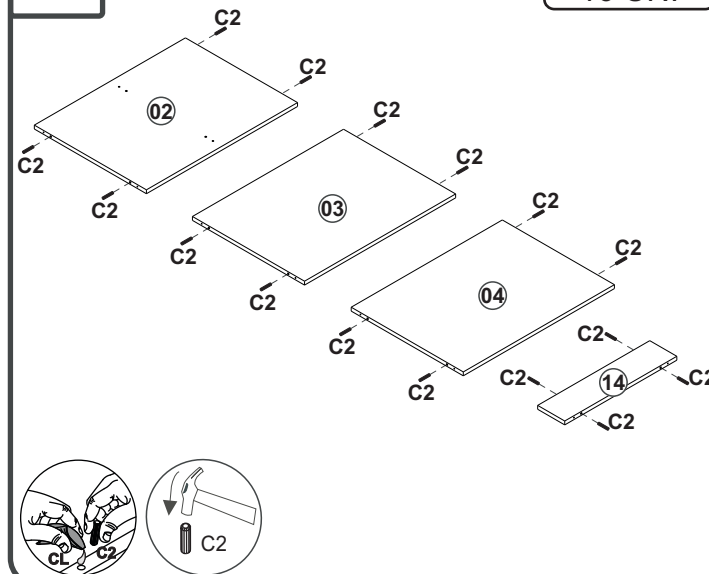

C2
 16 UNI

03°

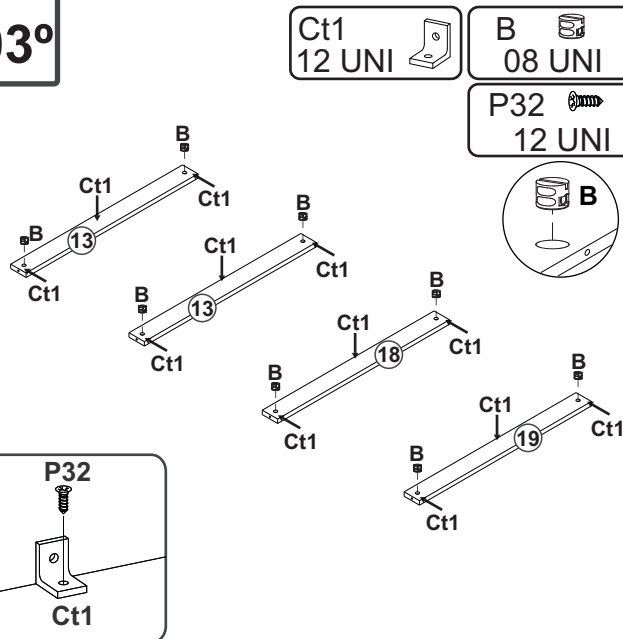

Ct1
 12 UNI

B
 08 UNI

P32
 12 UNI

04°

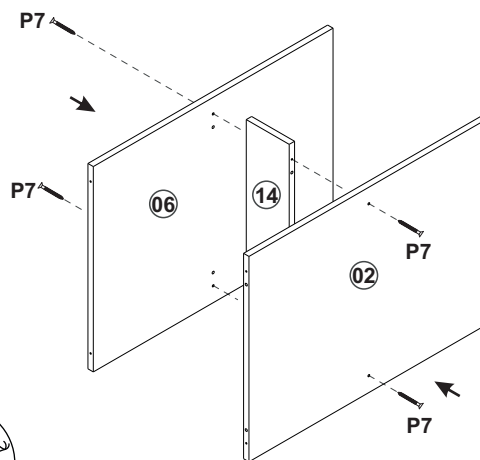

P7
 4 UNI

05°

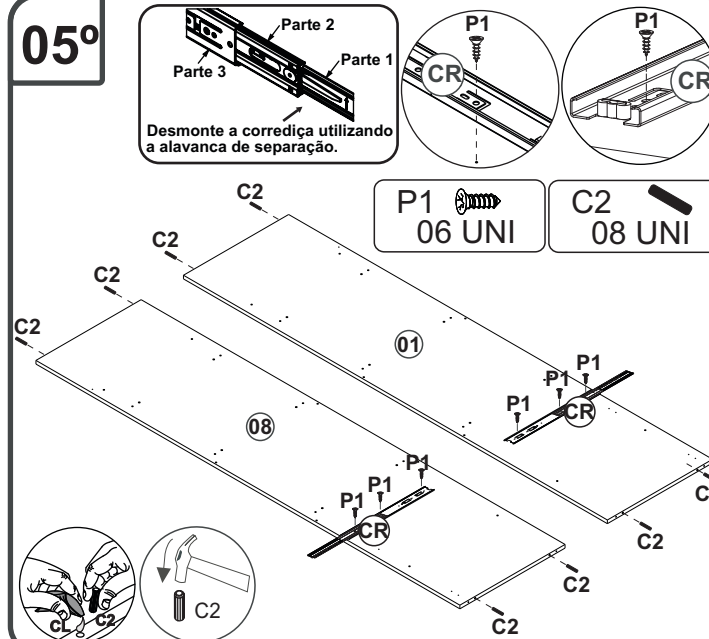

P1
 06 UNI

C2
 08 UNI

CO7310 - TORRE QUENTE 0,7 M

Manual de Montagem
Assembly Instructions
Instrucción de Montaje

decibal[®]
móveis

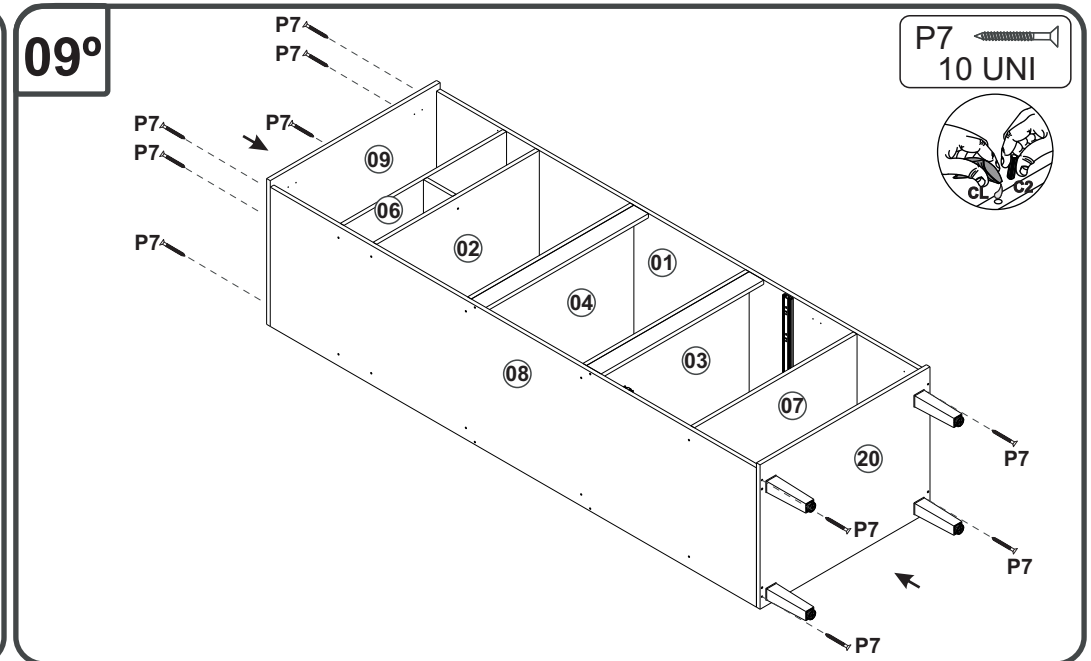
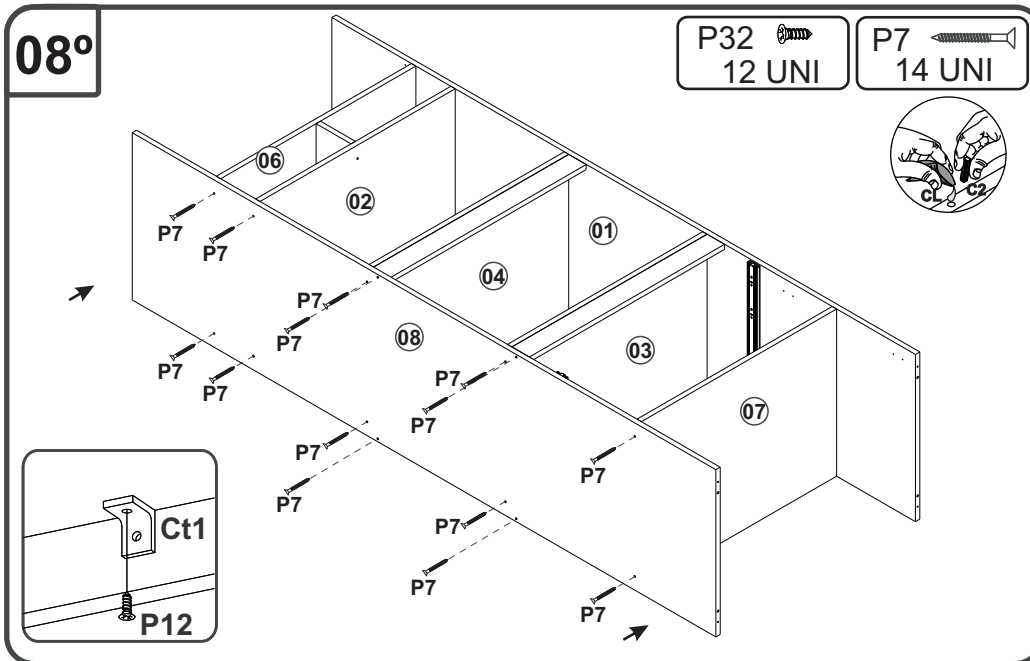
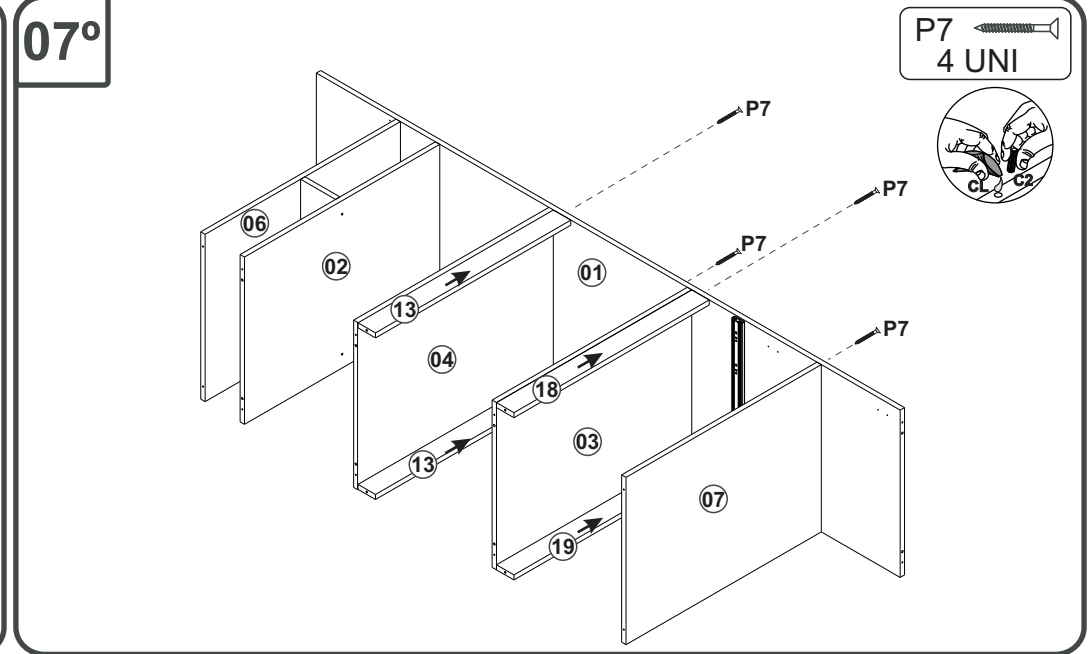
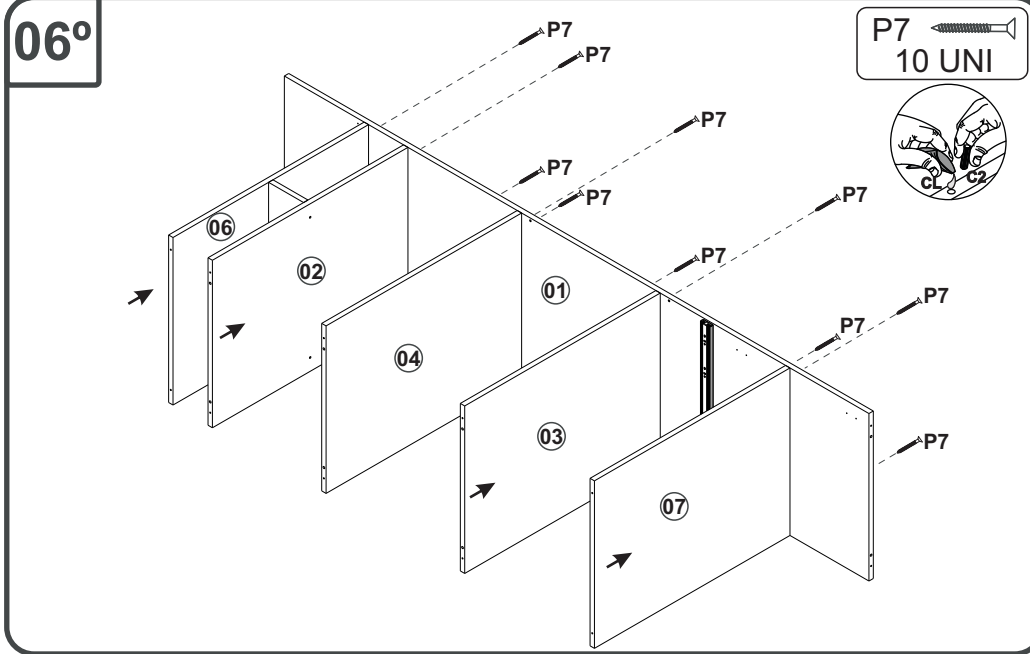

CO14401 - MÓDULO FORNO

Manual de Montagem
 Assembly Instructions
 Instrucción de Montaje

decibal[®]
 móveis

10° COSTA/REVÉS/BACK

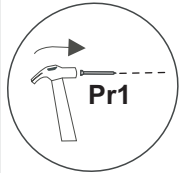

P1
4 UNI

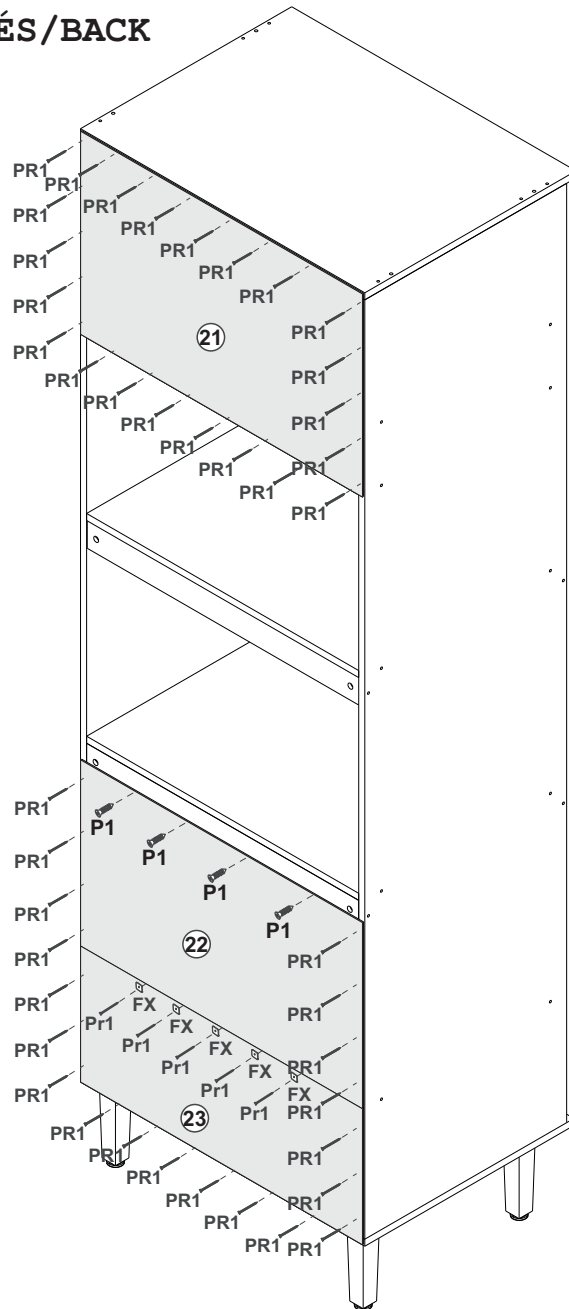

11°

P32
04 UN

C2
06 UN

Ct1
02 UN

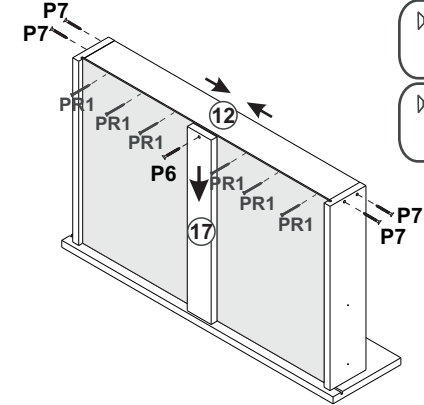
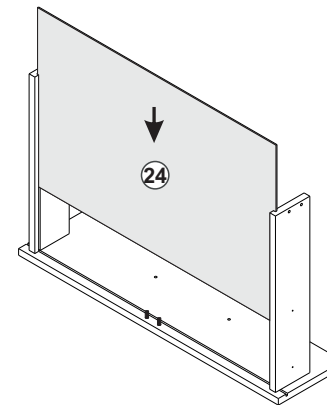
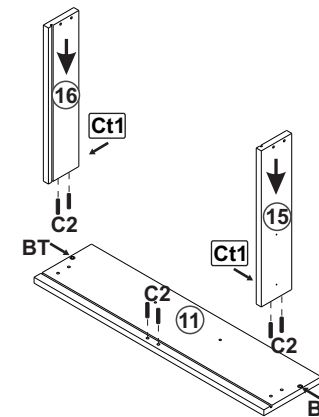
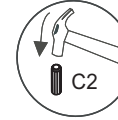
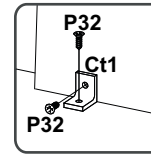

P7
04 UN

P6
01 UN

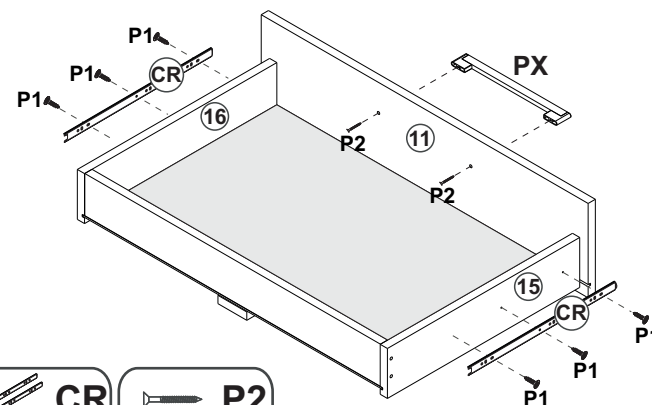

P1
06 UN

CR
01 UN

P2
02 UN

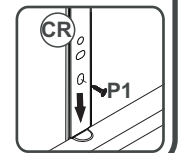
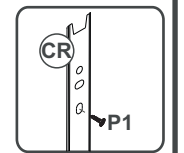

CO14401 - MÓDULO FORNO

Manual de Montagem
Assembly Instructions
Instrucción de Montaje

decibal[®]
móveis

12°



*PESO SUPORTADO.
*PESO SOPORTADO.
*WEIGHT SUPPORTED.

Fixação parede
Fixed in the wall

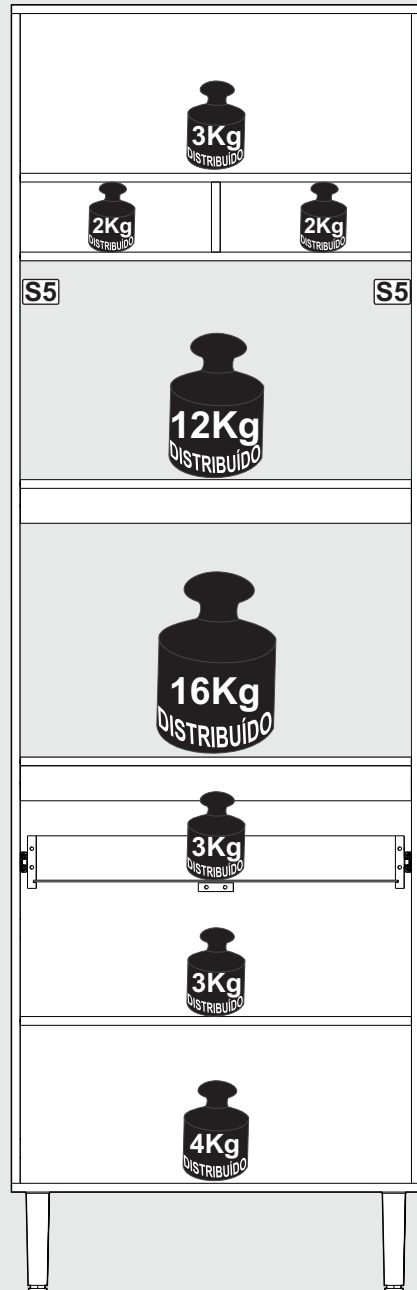
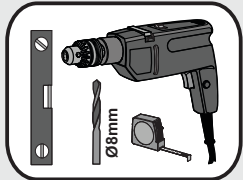
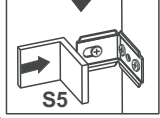
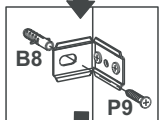
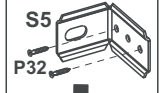

13°

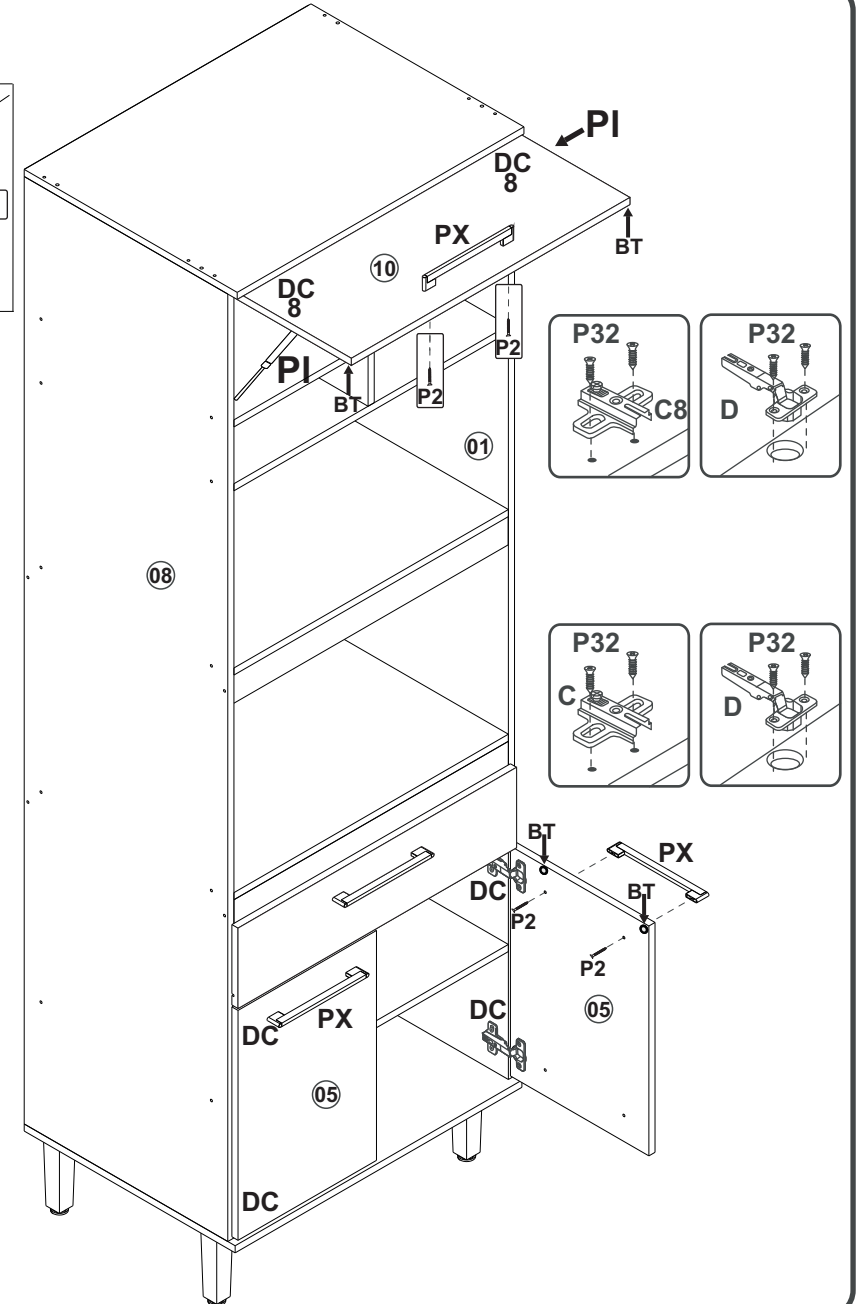
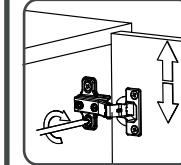
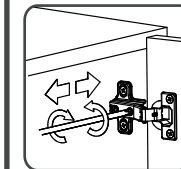
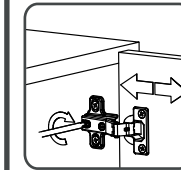
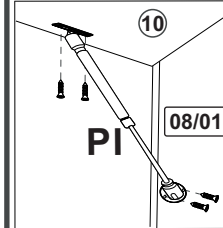

CO7310 - TORRE QUENTE 0,7 M



Manual de Montagem
Assembly Instructions
Instrucción de Montaje

decibal[®]
móveis

Relação de Peças/ Relación de Piezas/Parts List

Nº	CÓDIGO/CODE	DESCRIÇÃO/DESCRIPCIÓN/DESCRIPTION	QTD/CANT	VOL.
1	0569134	LATERAL DIR/LATERAL/SIDE	2003X497X15MM	1
2	0569137	TAMPO SUP MICRO/TAPA/TOP	670X497X15MM	1
3	0569136	TAMPO/TAPA/TOP	670X497X15MM	1
4	0541442	TAMPO MICRO/TAPA/TOP	670X497X15MM	2
5	0569143	PORTA INFERIOR/PUERTA/DOOR	486X338X15MM	2
6	0569139	BASE NICHOS	670X497X15MM	1
7	0569145	PRATELEIRA BALCAO/ESTANTE/SHELF	670X497X15MM	1
8	0569146	LATERAL ESQ/LATERAL/SIDE	2003X497X15MM	1
9	0569142	BASE SUP	520X700X15MM	1
10	0569141	PORTA SUP BASCULANTE	680X280X15MM	2
11	0569151	FRENTE GAVETA/FRENTE CAJÓN/DRAWER FRONT	680X170X15MM	2
12	0569149	BATENTE/REVÉS CAJÓN/DRAWER BACK	615X76X15MM	2
13	0541441	TRAVESSA MICRO/TRAVIESSA/TRVERSE	670X60X15MM	2
14	0569147	DIVISORIA SUP/DIVIDER	120X497X15MM	2
15	0569153	LAT GAV ESQ/LATERAL CAJÓN/DRAWER SIDE	400X90X15MM	2
16	0569150	LAT GAV DIR/LATERAL CAJÓN/DRAWER SIDE	400X90X15MM	2
17	0541430	TRAV GAVETA/TRAVIESSA/TRVERSE	400X60X15MM	2
18	0569140	TRAVESSA FRT/TRAVIESSA/TRVERSE	670X60X15MM	2
19	0569144	TRAVESSA TRS/TRAVIESSA/TRVERSE	670X60X15MM	2
20	0569135	BASE INF	700X515X15MM	2
21	0569138	COSTA SUP/REVÉS/BACK	694X433X2,8MM	2
22	0569247	COSTA/REVÉS/BACK	694X397X2,8MM	2
23	0569140	COSTA INF/REVÉS/BACK	694X290X2,8MM	2
24	0569152	FUNDO GAVETA/FONDO CAJÓN/DRAWER BOTTOM	624X405X2,8MM	2

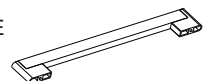
Escala (N/A)

LEGENDA	DESCRIÇÃO/DESCRIPCIÓN/DESCRIPTION	CÓDIGO	QUANT.
PX	PUXADOR/PEGADOR /HANDLE SEVILHA NEW GOLD 192 MM 	13106	04
PE	 PÉ/PATA/FOOT (170MM)	12003 Champagne	04
CR	 CORREDICA/CORREDERA/METTALIC SLIDE LARG	02641 350 MM	01
PI	 PISTÃO GÁS / PISTÓN DE GAS /GAS PISTON	12648 40N	02
Ct1	 CANTONEIRA/PIEZA L/SHEET	03077	14
B8	 BUCHA/BUJE/BUCHING (8mm)	01311	02

ATENÇÃO!!!! montadores e consumidores

- * Para limpar o móveis utilize somente um pano úmido (umedecido em água pura ou água com sabão neutro). Depois, passe um pano seco. Evite a umidade excessiva.
- * Evite usar álcool, água sanitária, detergente e outros produtos químicos, mesmo diluídos em água.
- * Não utilize produtos abrasivos de nenhuma espécie

ATENCIÓN!!!! montadores e consumidores

- * Para limpiar el mueble utilice solamente un paño húmedo (humedecido con agua limpia o con un jabón suave). A continuación, utilice un paño seco. Evite el exceso de humedad.
- * Evite uso de alcohol, hipocloridro solución basada, detergente y otros productos químicos, mismo diluídos en agua. No utilice productos abrasivos de ningún tipo.

ATTENTION!!!! assemblers and consumers

- *To clean the furniture, use only a damp cloth (humidify it only in pure water ou water and neutral soap). After, use a dry cloth.Avoid excessive humidity.
- *Avoid using alcohol, bleach, detergent and other chemical products, even diluted in water. Do not use any kind of abrasive cleaning agents to clean the furniture.
- The use of such products may jeopardize the ?nal characteristics of the furniture.

- ATENÇÃO!!!! montadores e consumidores
* Ajustar o torque da parafusadeira para não danificar as peças escareando o parafuso *
- ATENCIÓN!!!! montadores e consumidores
* Ajuste el torque del destornillador para no dañar las piezas avallanando el tornillo *
- ATTENTION!!!! assemblers and consumers
* Adjust the torque of the screwdriver so as not to damage the parts by countersinking the screw *

Ferramentas necessárias
Necessary tools
Herramientas necesarias



www.decibal.com.br



45 min.





















2 montador
2 ajustador
2 Fitter

CO7310 - TORRE QUENTE 0,7 M

Manual de Montagem
Assembly Instructions
Instrucción de Montaje

decibal[®]
móveis

Escala (1:1) Ferragens/ Herrajes/ Hardware				Escala (1:1) Ferragens/ Herrajes/ Hardware			
LEGENDA	DESCRIÇÃO/DESCRIPCIÓN/DESCRIPTION	CÓDIGO	QUANT.	LEGENDA	DESCRIÇÃO/DESCRIPCIÓN/DESCRIPTION	CÓDIGO	QUANT.
P1	 PARAFUSO/TORNILLO/SCREW 3X12	01328	16	B	BUCHA/BUJE/BUCHING 	02734	08
P2	 PARAFUSO/TORNILLO/SCREW 3,5X25	03130	08	Escala (N/A)			
P6	 PARAFUSO/TORNILLO/SCREW 4X35	02032	01	CL	 COLA/PEGAMENTO/GLUE	01213	01
P7	 PARAFUSO/TORNILLO/SCREW 4X45	01318	46	ET	 ETIQUETA LOGO DECIBAL/LABEL DECIBAL	01312	01
P8	 PARAFUSO/TORNILLO/SCREW 5X45	01320	04	S5	 SUPORTE AÉREO/APOYO AÉREO/AIR SUPPORT	03828	02
P9	 PARAFUSO/TORNILLO/SCREW 6X50	03827	02	FX	 FIXADOR COSTA/FIJADOR FONDO/FIXER COAST	01331	06
P32	 PARAFUSO/TORNILLO/SCREW 4X14	12412	64	AD	 ADESIVO/ADHESIVO/ADHESIVE	15mm	30
C2	 CAVILHA/TARUGO/DOWEL 6X30MM	01211	32	BT	 BATENTE/BATIENTE DE SILICONA/SILICONE STOP 8MM	02921	08
PU	 PARAFUSO UNIÃO/UNIÓN DETORNILLO /SCREW UNION	01495	02	DC	 DOBRADIÇA/BISAGRA/HINGE D=35mm C= Alta	12615 (Amortecimento)	04
PR1	 PREGO/CLAVO/NAIL 10X10	01330	55	DC8	 DOBRADIÇA/BISAGRA/HINGE D=35mm C=8mm	04043	02

Medida em mm

