

Manual de montagem / Plano de armado

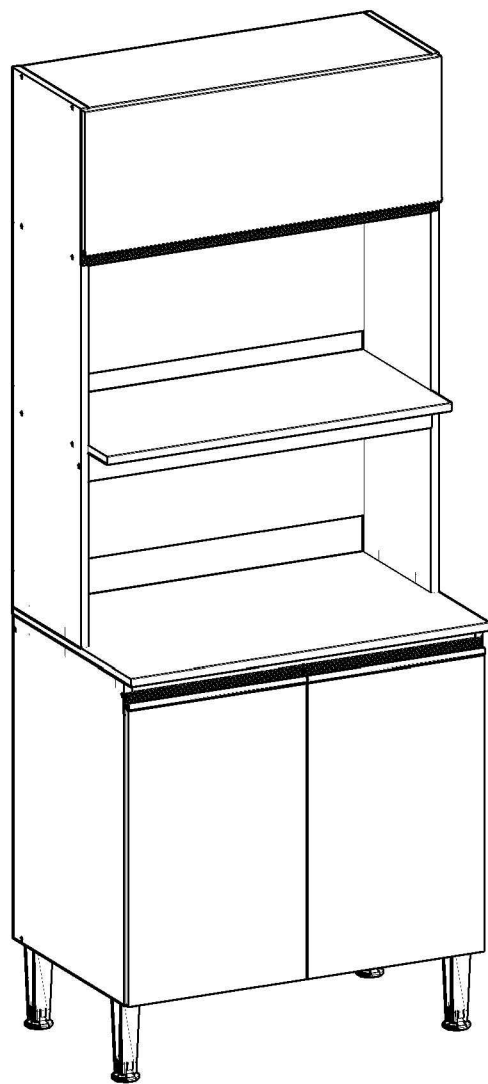

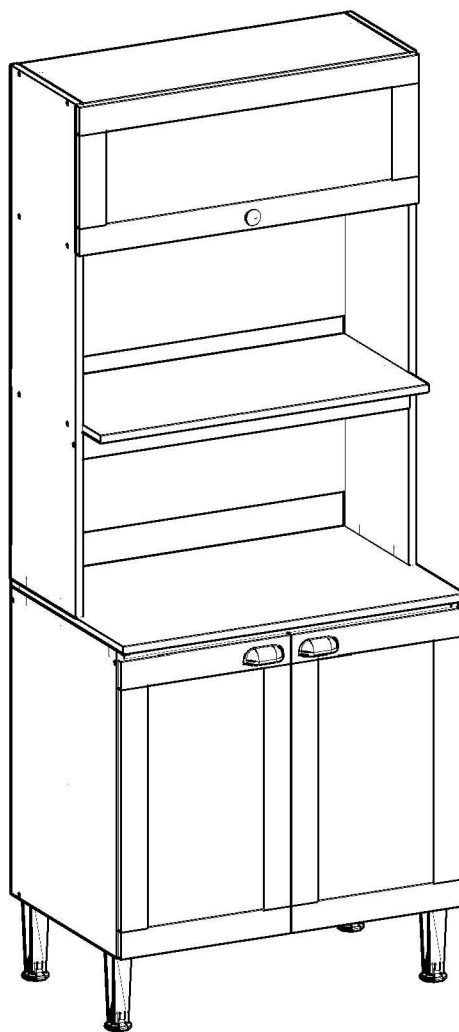

GenialFlex
móveis

Ref.: 1311M

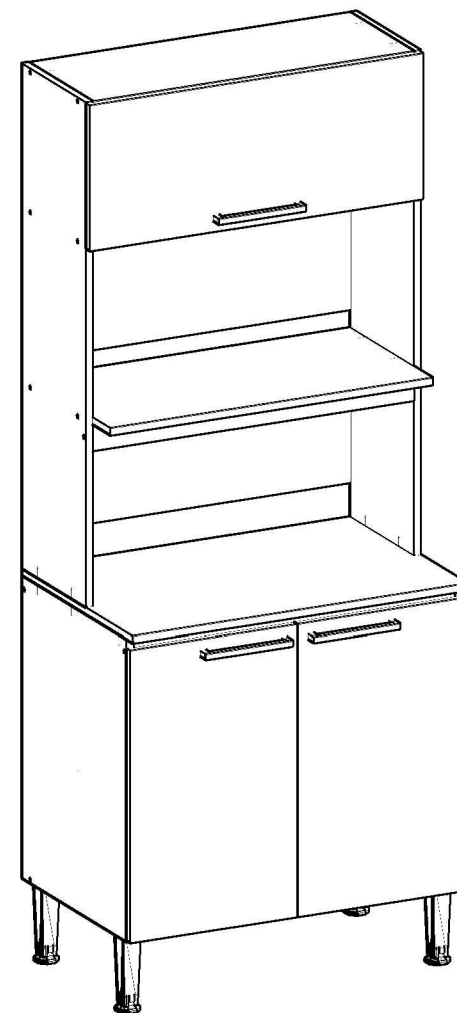

Ref.: 1311P



Ref.: 1311L

Parabéns! Você comprou um produto de excelente qualidade, fabricado com chapa de madeira de MDP ou MDF, extraída de florestas renováveis. Possui alta resistência e design atual.

Felicitaciones! Usted compró a un producto de excelente calidad, fabricado con placa de madera de MDP o MDF, proveniente de florestas renovables. Tiene alta resistencia y diseño actual.

Antes de montar o móvel, leia com atenção o manual de montagem!

Antes de armar el mueble, lea con atención el manual de ensamble!



ATENÇÃO:
ATENCIÓN:

1) Verifique todas as peças antes de começar a montagem.

Verifique todas las partes antes de empezar el armado.

2) Ao começar a montagem, não apoie as peças na parede.

Al empezar el armado, no apoyes las partes en la pared.

3) Ao colocar as peças e ferragens de lado, cuidado para não perde-las.

Al poner las piezas y herrages a parte, cuidado para no dañarlas.

4) O móvel deve ser montado no chão, para isso, use a própria caixa para proteger e não danificar o piso.

El mueble suele ser armando al piso, para eso, use la propia caja para protegerlo y no dañar al piso.

5) Comece a montagem seguindo as instruções passo a passo.

Comience el armado siguiendo la instrucciones paso a paso.

6) É de responsabilidade do montador seguir as intrucões desse manual, que são fundamentais para a estrutura do móvel.

Es de responsabilidad del armador seguir las instrucciones de este manual, que son fundamentales para la estructura del mueble.

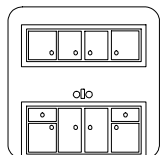

CUIDADOS:
CUIDADOS:

1) A conservação e limpeza deve ser feita com um pano levemente umedecido com água.

La conservación y limpieza debe ser hecha con un trapo levemente humedecido en agua.

2) Não use produtos abrasivos, como saponáceo, detergentes e esponja de aço.

No use productos abrasivos, como saponáceo, detergentes y esponja de acero.

3) Não use cera ou óleo para dar brilho ao móvel.

No use cera o aceites para darle brillo al mueble.



4) Não expor o móvel a interpéries e nem ao calor excessivo.

No exponer el mueble a interperies ni al calor excesivo.

5) Ao terminar a montagem, limpe o ambiente e o móvel.

Al terminar el armado, limpie al ambiente y al mueble.

FERRAMENTAS:
HERRAMIENTAS:

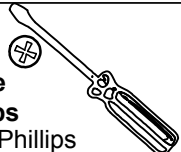
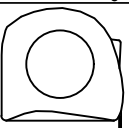





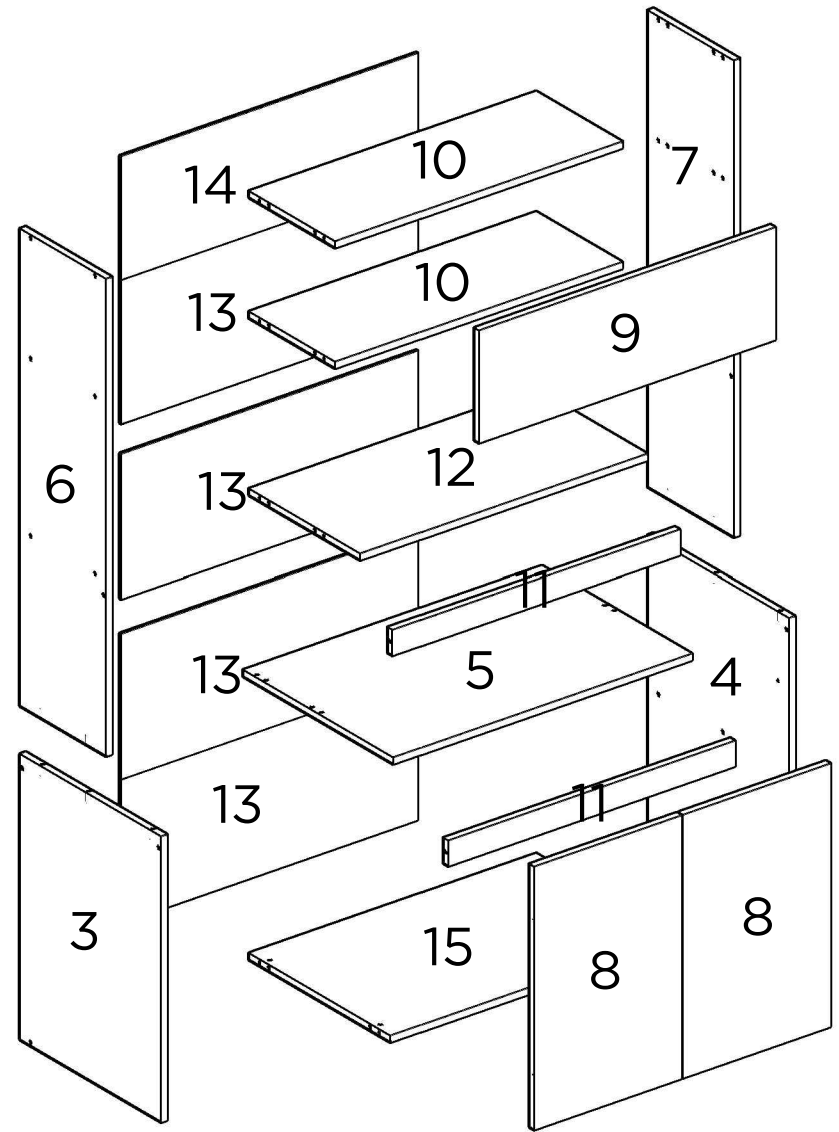



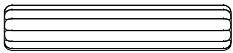
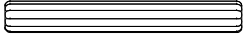

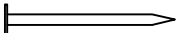

 Parafusadeira Destornillador Eléctrico	 Martelo de borracha Martillo Goma	 Martelo Martillo
 Chave Phillips Llave Phillips	 Trena Cinta métrica	

PEÇAS / PARTS / PIEZAS

Nº No Num	DESCRIÇÃO DESCRIPTION DESCRIPCIÓN	QTD QTY CANT
15	BASE BOTTOM BASE	1
2	TAMPO SUPERIOR UPPER TOP TABLERO SUPERIOR	1
3	LATERAL ESQUERDA INFERIOR LOWER LEFT SIDE PANEL LATERAL IZQUIERDA INFERIOR	1
4	LATERAL DIREITA INFERIOR LOWER RIGHT SIDE PANEL LATERAL DERECHA INFERIOR	1
5	TAMPO INFEIROR LOWER TOP PANEL TABLERO INFERIOR	1
6	LATERAL ESQUERDA SUPERIOR UPPER LEFT SIDE PANEL LATERAL IZQUIERDA SUPERIOR	1
7	LATERAL DIREITA SUPERIOR UPPER RIGHT SIDE PANEL LATERAL DERECHA SUPERIOR	1
8	PORTA DOOR PUERTA	2
9	PORTA BASCULANTE TILTING DOOR PUERTA BASCULANTE	1
10	PRATELEIRA PLATE PANEL REPISA	2
11	TRAVESSA PLATE PANEL TRAVESAÑO	2
12	BASE FORNO OVEN BOTTOM BASE HORNO	1
13	COSTA INFERIOR LOWER BACK PANEL TRASERO INFERIOR	4
14	COSTA SUPERIOR UPPER BACK PANEL TRASERO SUPERIOR	1

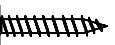

FERRAGENS / HARDWARE / HERRAJES

CÓD CODE COD	DESCRIÇÃO DESCRIPTION DESCRIPCIÓN	QTD QTY CANT
A	 CAVILHA WOODEN DOWEL TARUGO	18
B	 CAVILHA 6X50mm WOODEN DOWEL 6X50mm TARUGO 6x50mm	4
C	 PARAFUSO 4X14mm SCREW 4X14mm TORNILLO 4X14mm	49
D	 CANTONEIRA DE 2 FUROS METALLIC ANGLE CANTONERA 2 AGUJEROS	8
E	 PARAFUSO 3,5X40mm SCREW 3,5X40mm TORNILLO 3,5X40mm	28
F	 PARAFUSO 5X50mm SCREW 5X50mm TORNILLO 5X50mm	5
G	 PÉ LEG PATA	4
H	 PERFIL I PROFILE I PERFIL I	1
I	 PREGO NAIL CLAVO	48
J	 GARRA METÁLICA METALLIC CLAW GRAB METALICA	4
K	 SUPORTE DE FIXAÇÃO MOUNTING SUPPORT SOPORTE DE MONTAJE	1
L	 BUCHA PLÁSTICA PLASTIC BUSHING CASQUILLO PLÁSTICO	1
M	 CALÇO PARA DOBRADIÇA HINGE SHED CALZO DE BISAGRA	6
N	 DOBRADIÇA HINGE BIZAGRA	6
O	 PARAFUSO 3,5X25mm SCREW 3,5X25mm TORNILLO 3,5X25mm	3
P	 PISTÃO PISTON PISTÓN	1
Q	 PUXADOR PULLER TIRADOR	3
R	 PARAFUSO 3,5X25mm SCREW 3,5X25mm TORNILLO 3,5X25mm	6

UTILIZE A RÉGUA PARA IDENTIFICAR OS PARAFUSOS
USE THE RULER TO IDENTIFY THE SCREWS
UTILICE LA REGLA PARA IDENTIFICAR LOS TORNILLOS

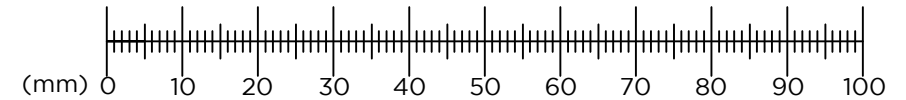

PESO SUPORTADO / WEIGHT SUPPORTED / PESO SOPORTADO

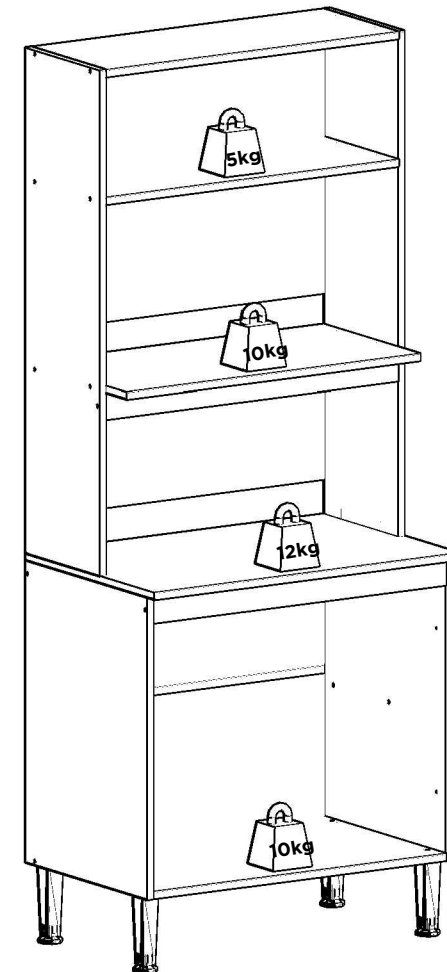

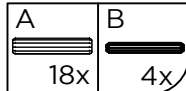
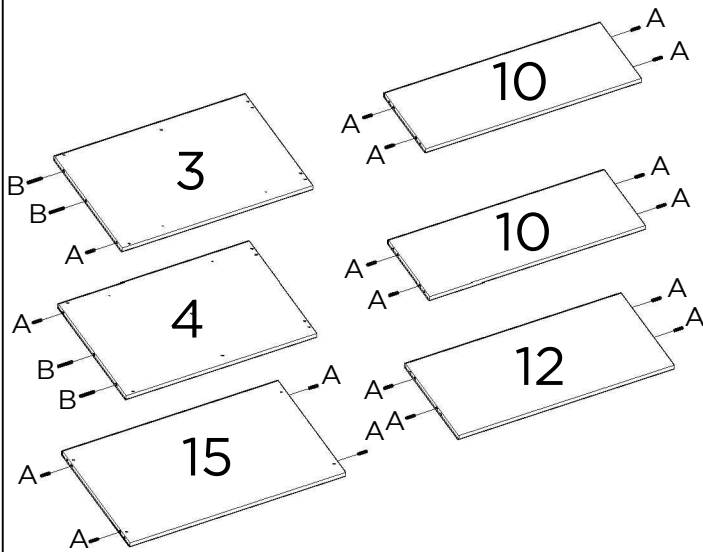
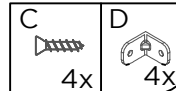
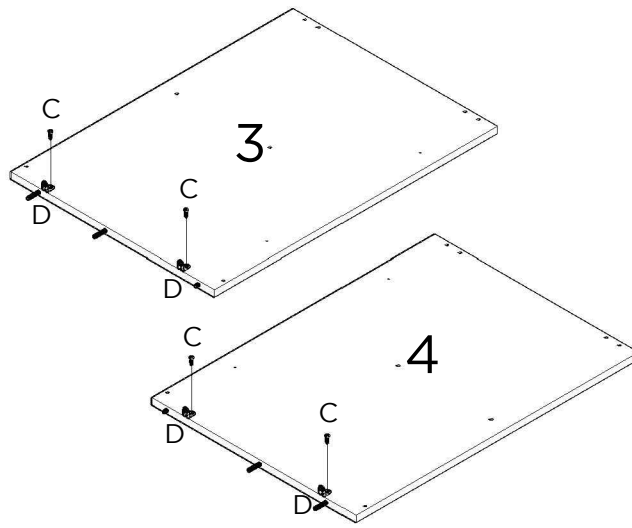
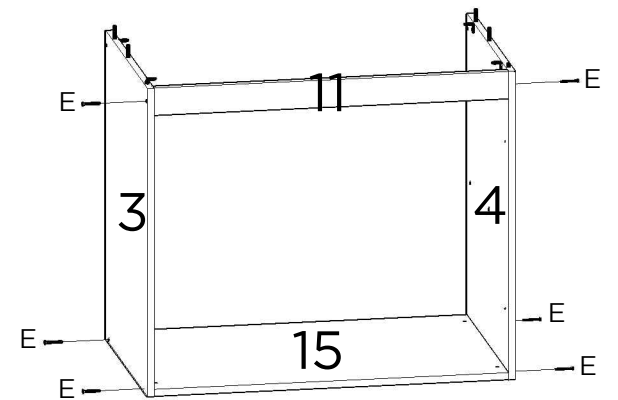
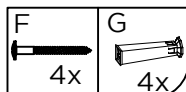
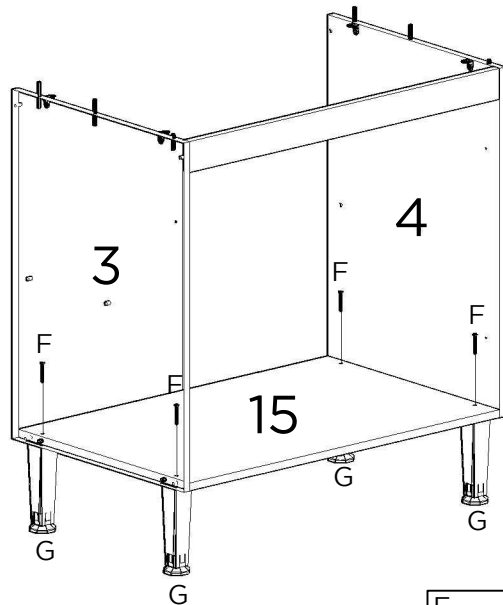
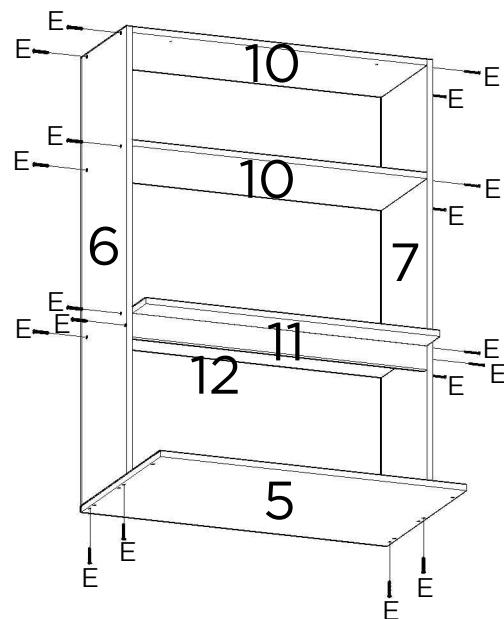
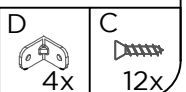
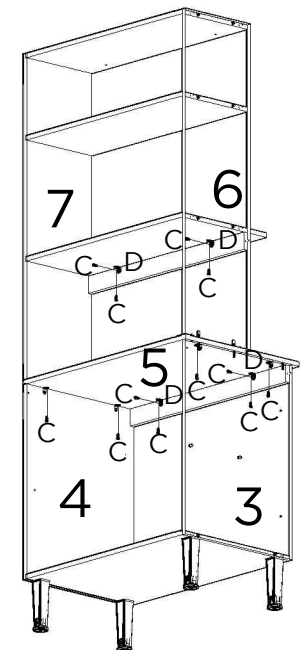
1**2****3****4****5****6**

7

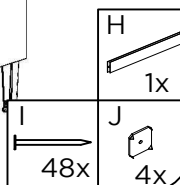
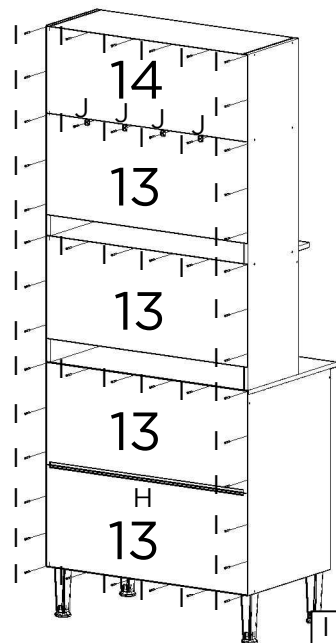
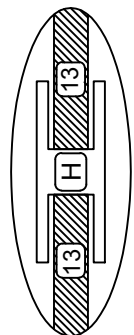

8

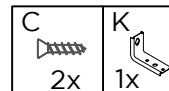
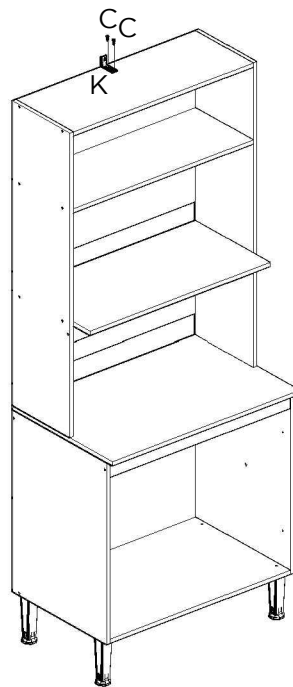

9

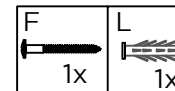
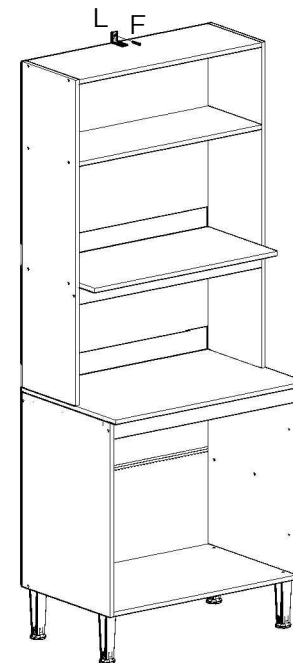

USE A BUCHA DE ACORDO COM O MATERIAL DA PAREDE
 USE LA BUJE DE ACUERDO CON EL MATERIAL DE LA PARED
 USE THE BUSHING ACCORDING TO THE WALL MATERIAL

MATERIAL DA PAREDE: Painel de gesso ou estuque com viga de madeira;
SISTEMA DE FIXAÇÃO: Parafuso de fixação inserido diretamente na viga de madeira.

WALL MATERIAL: Plaster or stucco panel with wooden beam;
FIXING SYSTEM: Fixing screw inserted directly into the wooden beam.

MATERIAL DE LA PARED: Panel de yeso o estuco con viga de madera;
SISTEMA DE FIJACIÓN: Tornillo de fijación insertado directamente en la viga de madera.

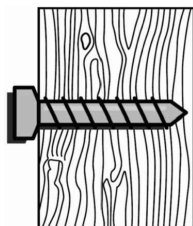

MATERIAL DA PAREDE: Painel de gesso sem viga de madeira;
SISTEMA DE FIXAÇÃO: Parafuso de fixação com bucha plástica.

WALL MATERIAL: Plaster panel without wooden beam;
FIXING SYSTEM: Fixing screw with plastic bushing.

MATERIAL DE LA PARED: Panel de yeso sin viga de madera;
SISTEMA DE FIJACIÓN: Tornillo de fijación con buje de plástico.

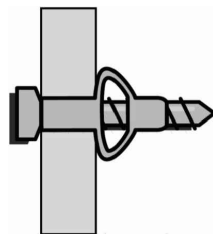

MATERIAL DA PAREDE: Alvenaria (concreto ou tijolo);
SISTEMA DE FIXAÇÃO: Parafuso de fixação com bucha.

WALL MATERIAL: Masonry (concrete or brick);
FIXING SYSTEM: Fixing screw with plastic bushing.

MATERIAL DE LA PARED: Albañilería (hormigón o ladrillo);
SISTEMA DE FIJACIÓN: Tornillo de fijación con buje de plástico.

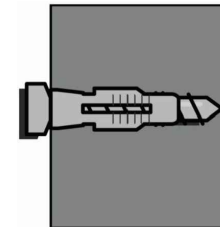

10

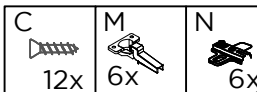
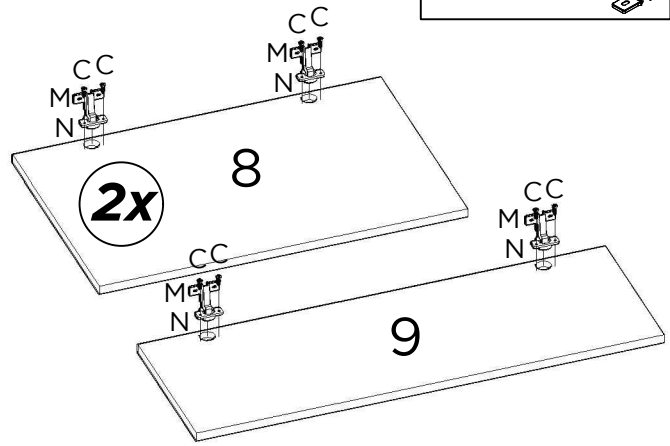
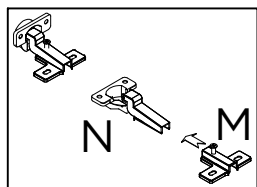

11

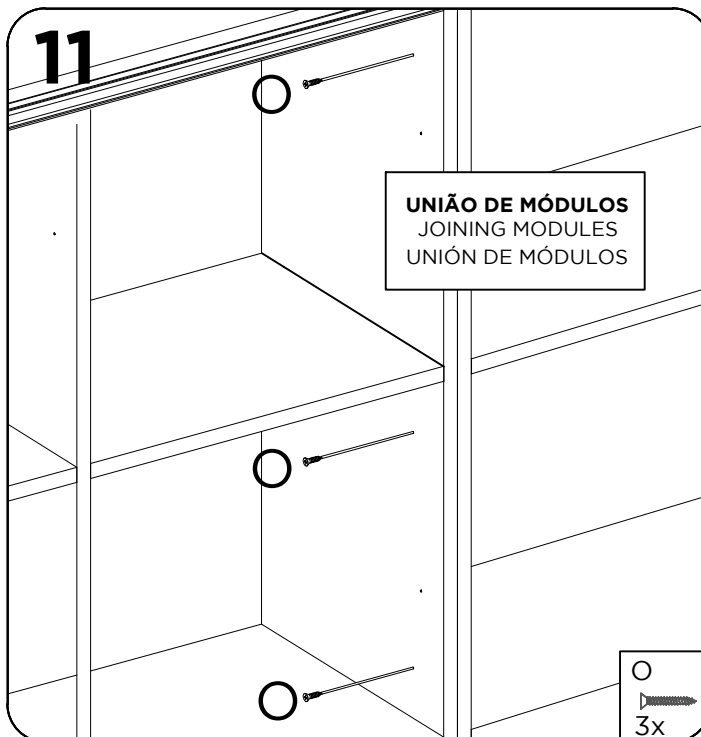

UNIÃO DE MÓDULOS
JOINING MODULES
UNIÓN DE MÓDULOS



12

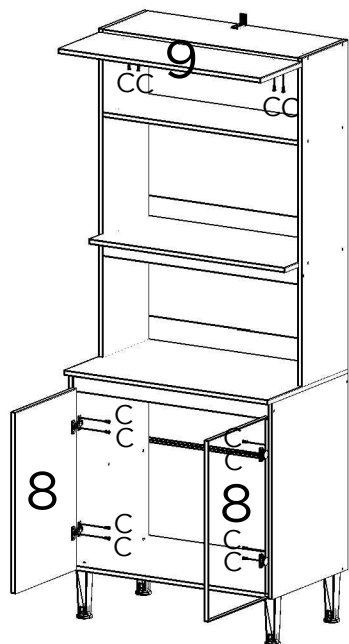

PARA EFETUAR A INSTALAÇÃO DO PISTÃO, SIGA OS PASSOS NO MANUAL QUE O ACOMPANHA.
TO INSTALL THE PISTON, FOLLOW THE STEPS IN THE ACCOMPANYING MANUAL.
PARA INSTALAR EL PISTÓN SEGUIR LOS PASOS DEL MANUAL ADJUNTO.

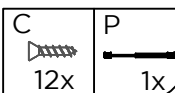

Instalação dos puxadores conforme modelo adquirido, siga os passos no manual dos puxadores.

Instalación de las manijas según el modelo adquirido, seguir los pasos del manual de manijas.

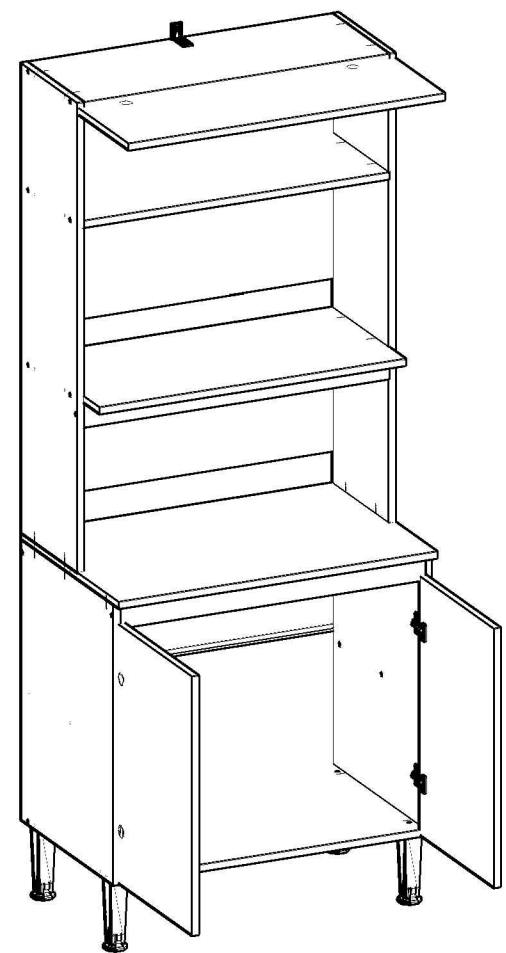

Instalação do puxador. Instalación del tirador

Siga a instrução de montagem do puxador segundo o modelo adquirido. Utilizando as respectivas ferragens.

Siga las instrucciones de montaje del tirador según el modelo adquirido. Usar correctamente la herraje.

