

**HENN**Ind. e Com. de Móveis Henn  
Mondai - SC - Brasil

☎ +55 49 3674.3500

📷 📱 @moveishenn  
www.henn.com.br**INSTRUÇÕES DE  
MONTAGEM**INSTRUCCIONES DE MONTAJE  
ASSEMBLY INSTRUCTIONS**Torre Quente 02 Fornos 715mm Requite |**

Torre Caliente 02 Hornos 715mm Requite | Hot Tower 02 Ovens 715mm Requite

C643-217 Nature/Areia HP

C643-218 Nature/Nature/Areia HP

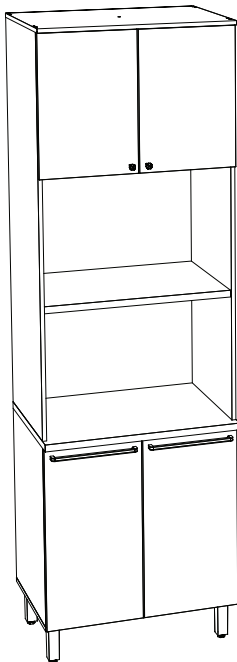
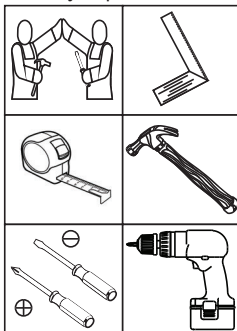
Requisitos para montagem  
Requisitos para la montaje  
Assembly RequirementsImagens meramente ilustrativas,  
não acompanha o produto.  
Imágenes ilustrativas, no incluidas  
con el producto.  
Illustrative images, not included  
with the product.**AVISO**

Para limpeza de seu móvel, use uma franela seca ou umedecida, e não utilize produtos químicos que possam danificar seu produto.

**SISTEMA DE MONTAGEM**

O sistema de montagem dos produtos, funciona de acordo com a ordem crescente dos números indicados no desenho. Ex: 01, 02, 03, 04... até a conclusão da montagem.

**ASSISTÊNCIA TÉCNICA**

Para solicitação de Assistência Técnica você consumidor deverá entrar em contato com o Lojista a qual você realizou a compra deste produto e solicitar a assistência técnica das peças avariadas. A garantia abrange todas as peças, partes e componentes que eventualmente venham apresentar defeito de fabricação no prazo de 03 (três) meses, contando a partir da entrega do produto ao consumidor, mediante nota fiscal de compra. Se houver qualquer alteração na estrutura do produto ou ocorrer defeito por negligência do montador/consumidor em relação a instrução de montagem e manuseio, não será fornecido assistência técnica gratuita.

**ADVERTENCIA**

Para limpieza de su móvil, use una franela seca o húmeda, y no utilice productos químicos que puedan dañar su producto.

**SISTEMA DE MONTAJE**

El sistema de montaje de los productos funciona de acuerdo con el orden creciente de los números indicados en el dibujo. Ej.: 01, 02, 03, 04... hasta la conclusión del montaje.

**ASISTENCIA TÉCNICA**

Para solicitar Asistencia Técnica, el consumidor debe comunicarse con el Comercio que usted realizó la compra de este producto y solicita asistencia técnica para las partes dañadas. La garantía cubre todas las partes, piezas y componentes que eventualmente puedan presentar defecto de fabricación en el plazo de 03 (tres) meses, contados a partir de la entrega del producto al consumidor, mediante factura de compra. Si se produce algún cambio en la estructura del producto o se produce un defecto por negligencia del montador/consumidor en relación con las instrucciones de montaje y manipulación, no se prestará asistencia técnica gratuita.

**NOTICE**

To clean your furniture, use a dry or wet cloth, and do not use chemicals that may damage your product.

**ASSEMBLY SYSTEM**

The products' assembly system works according to the increasing order of the indicated numbers. For example: 01, 02, 03, 04 ... to the end of the assembly.

**TECHNICAL ASSISTANCE**

To request Technical Assistance, the consumer must contact the retailer from whom you purchased this product and request technical assistance for the damaged parts. The warranty covers all parts, parts and components that may eventually present a manufacturing defect within a period of 03 (three) months, counting from the delivery of the product to the consumer, by means of a purchase invoice. If there is any change in the structure of the product or defect occurs due to negligence of the assembler/consumer in relation to the assembly and handling instruction, free technical assistance will not be provided.

# ACESSÓRIOS | ACCESORIOS | ACCESSORIES

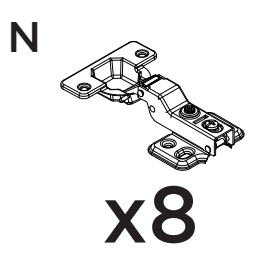
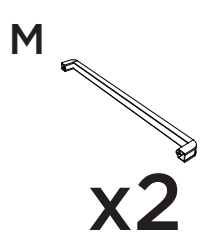
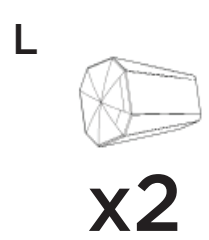
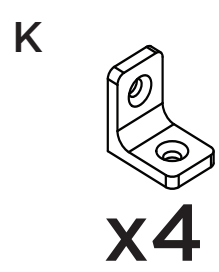
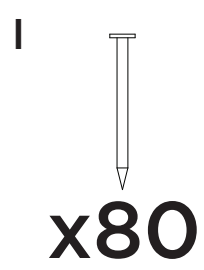
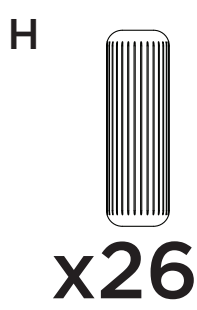
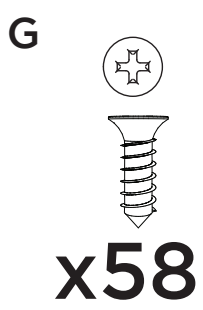
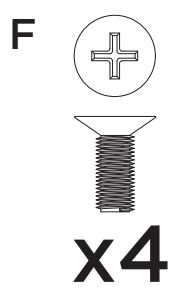
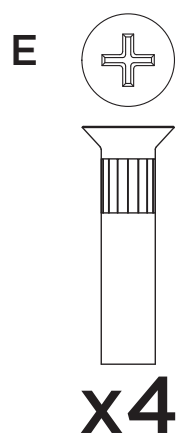
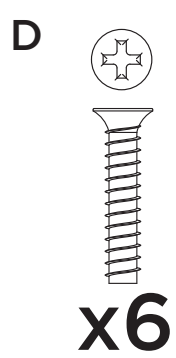
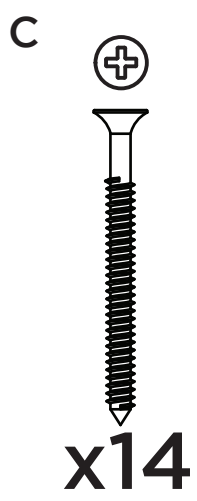
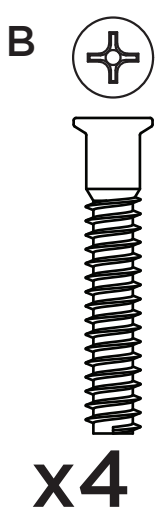
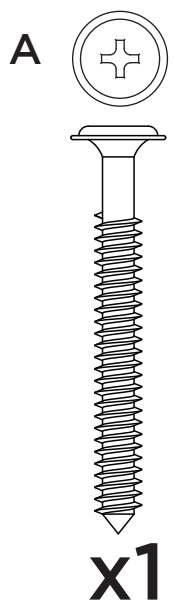

Parafusos em escala  
Tornillos escalados  
Scaled screws **1:1**

## ACESSÓRIOS | ACCESORIOS | ACCESSORIES

O

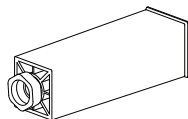

x4

P

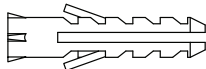

x1

Q

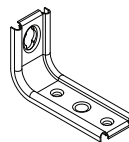

x1

R

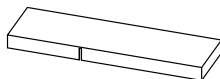

x1

S

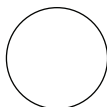

x16

T

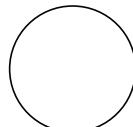

x12

U

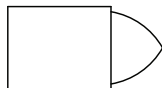

x3

V

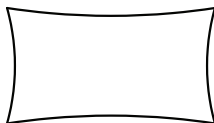

x1

W



x1

X



x4

Y

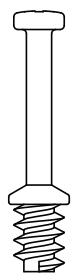

x8

Z



x8

Parafusos em escala  
Tornillos escalados  
Scaled screws 1:1



Os parafusos (E/F) devem ser usados somente quando este módulo for acoplado a outro módulo componível Henn.



Los tornillos (E/F) se debe utilizar sólo cuando el módulo está conectado a otro módulo componible Henn.



Screws (E/F) are to be used only when this module is mated to another Henn buildable module.

# LISTA DE PEÇAS | LISTA DE PIEZAS | LIST OF PIECES

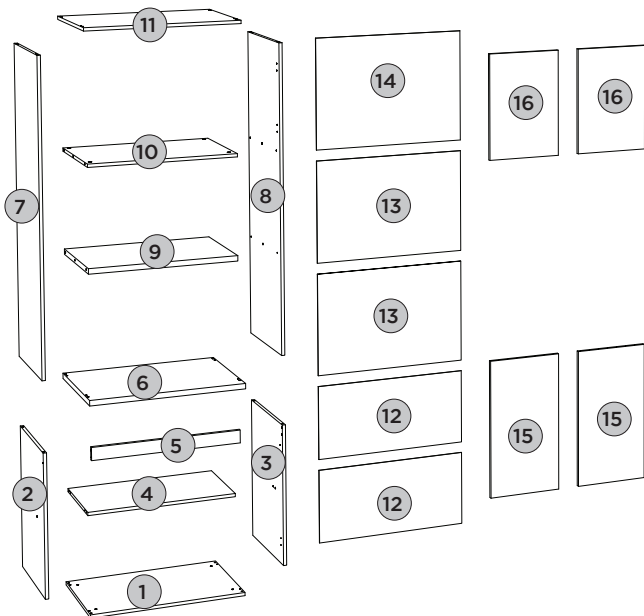

| Item | Caixa<br>Caja<br>Box | Qty<br>Ctd<br>Qty | Descrição<br>Descripción<br>Description                                       | Dimensões (mm)   Dimensiones<br>(mm)   Dimensions (mm) |                           |                                  |
|------|----------------------|-------------------|---|--|---------------------------|----------------------------------|
|      |                      |                   |   | Comprimento<br>Largo<br>Length                         | Largura<br>Ancho<br>Width | Espessura<br>Grosor<br>Thickness |
| 1    | 1/1                  | 01                | BASE   BASE   BASE  | 715  | 490                       | 15                               |
| 2    | 1/1                  | 01                | LATERAL ESQUERDA INFERIOR   LATERAL IZQUIERDA INFERIOR  <br>LEFT SIDE LOWER   | 660  | 490                       | 15                               |
| 3    | 1/1                  | 01                | LATERAL DIREITA INFERIOR   LATERAL DERECHA INFERIOR  <br>RIGHT SIDE LOWER     | 660  | 490                       | 15                               |
| 4    | 1/1                  | 01                | PRATELEIRA   ESTANTE   SHELF  | 684  | 400                       | 15                               |
| 5    | 1/1                  | 01                | TRAVESSA FRONTAL   TRAVESAÑO FRONTAL   FRONT CROSS-<br>BAR                    | 684  | 60                        | 15                               |
| 6    | 1/1                  | 01                | TAMPO 25MM   TAPA 25MM   TOP 25MM   | 715  | 533                       | 25                               |
| 7    | 1/1                  | 01                | LATERAL ESQUERDA SUPERIOR   LATERAL IZQUIERDA SUPE-<br>RIOR   UPPER LEFT SIDE | 1445   | 490                       | 15                               |
| 8    | 1/1                  | 01                | LATERAL DIREITA SUPERIOR   LATERAL DERECHA SUPERIOR  <br>UPPER RIGHT SIDE     | 1445   | 490                       | 15                               |
| 9    | 1/1                  | 01                | PRATELEIRA CENTRAL   ESTANTE CENTRAL   CENTRAL SHELF                          | 684  | 480                       | 25                               |
| 10   | 1/1                  | 01                | BASE AÉREO   BASE AEREO   AIR BASE  | 684  | 490                       | 15                               |
| 11   | 1/1                  | 01                | TAMPO   TAPA   TOP  | 715  | 517                       | 15                               |
| 12   | 1/1                  | 02                | FUNDO INFERIOR   FONDO INFERIOR   LOWER<br>BACKGROUND                         | 708  | 343                       | 3                                |
| 13   | 1/1                  | 02                | FUNDO CENTRAL   FONDO CENTRAL   CENTRAL FUND                                  | 708  | 475                       | 3                                |
| 14   | 1/1                  | 01                | FUNDO SUPERIOR   FONDO SUPERIOR   UPPER<br>BACKGROUND                         | 708  | 517                       | 3                                |
| 15   | 1/1                  | 02                | PORTA INFERIOR   PUERTA INFERIOR   LOWER DOOR                                 | 665  | 354                       | 15                               |
| 16   | 1/1                  | 02                | PORTA   PUERTA   DOOR   | 508  | 354                       | 15                               |





# PASSO 1

ITM/C643-

## PEÇAS REQUERIDAS

|   |                           |    |
|---|---------------------------|----|
| 1 | BASE                      | x1 |
| 2 | LATERAL ESQUERDA INFERIOR | x1 |
| 3 | LATERAL DIREITA INFERIOR  | x1 |
| 4 | PRATELEIRA                | x1 |
| 5 | TRAVESSA FRONTAL          | x1 |

## ACESSÓRIOS REQUERIDOS

|   |   |    |
|---|---|----|
| B |   | 04 |
| H |  | 14 |
| O |  | 04 |
| V |  |    |

## FERRAMENTAS NECESSÁRIAS

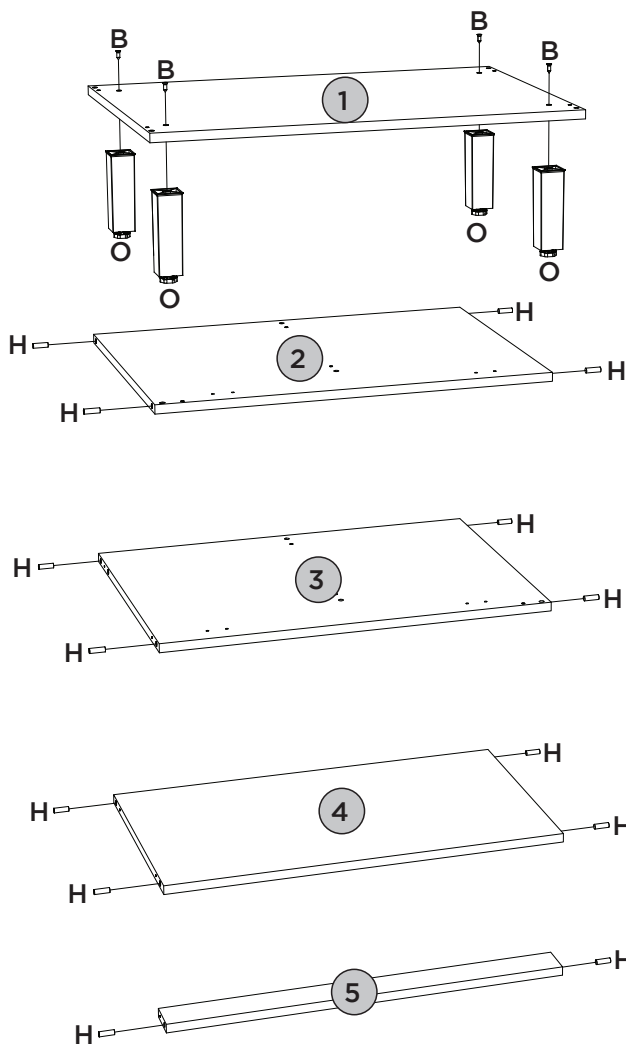
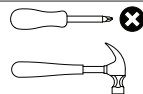

Utilizar o sachê de cola (V) em todas as cavilhas (H) do produto.

Con el pegamento sobre (V) en todos los pernos (H) producto.

Use the glue sachet (V) on all the pegs (H) of the product.



# PASSO 2

ITM/C643-

## PEÇAS REQUERIDAS

|    |                           |    |
|----|---------------------------|----|
| 7  | LATERAL ESQUERDA SUPERIOR | x1 |
| 8  | LATERAL DIREITA SUPERIOR  | x1 |
| 9  | PRATELEIRA CENTRAL        | x1 |
| 10 | BASE AÉREO                | x1 |

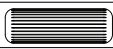
## ACESSÓRIOS REQUERIDOS

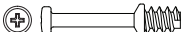
|   |   |    |
|---|---|----|
| H |  | 12 |
| V |  |    |
| Y |  | 08 |

## FERRAMENTAS NECESSÁRIAS

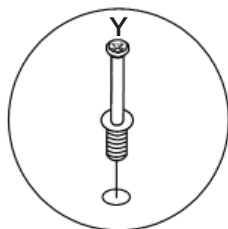
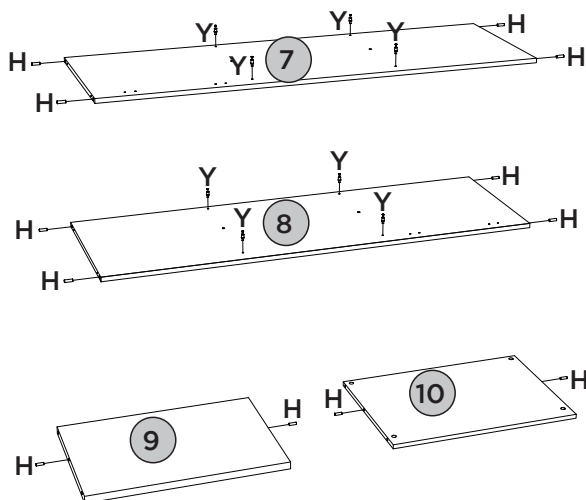
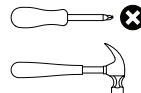



# PASSO 3

## PEÇAS REQUERIDAS

|   |                           |    |
|---|---------------------------|----|
| 1 | BASE                      | x1 |
| 2 | LATERAL ESQUERDA INFERIOR | x1 |
| 3 | LATERAL DIREITA INFERIOR  | x1 |
| 4 | PRATELEIRA                | x1 |
| 5 | TRAVESSA FRONTAL          | x1 |

## ACESSÓRIOS REQUERIDOS

|   |   |    |
|---|---|----|
| C |  | 10 |
| V |  |    |



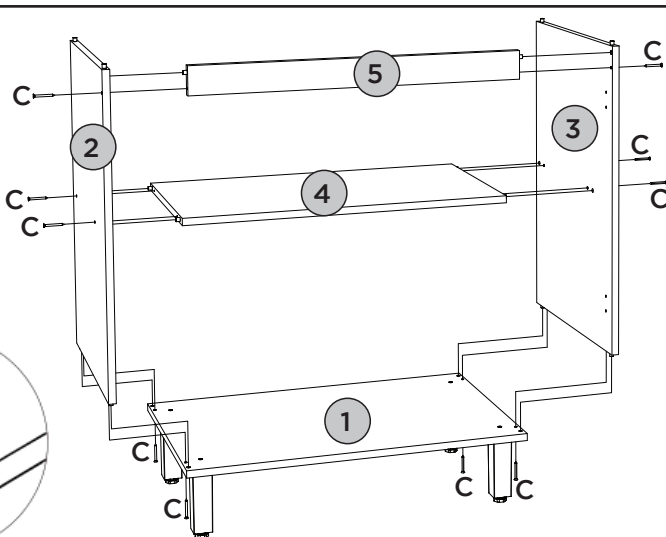
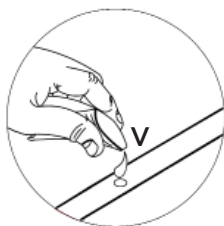
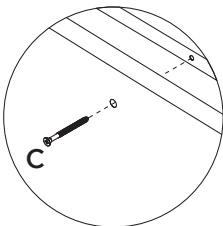
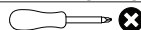

## FERRAMENTAS NECESSÁRIAS



**PEÇAS REQUERIDAS**

|    |                           |    |
|----|---------------------------|----|
| 6  | TAMPO 25MM                | x1 |
| 7  | LATERAL ESQUERDA SUPERIOR | x1 |
| 8  | LATERAL DIREITA SUPERIOR  | x1 |
| 9  | PRATELEIRA CENTRAL        | x1 |
| 10 | BASE AÉREO                | x1 |
| 11 | TAMPO                     | x1 |

**ACESSÓRIOS REQUERIDOS**

|   |   |    |
|---|---|----|
| C |  | 04 |
| V |  |    |
| X |  | 04 |
| Z |  | 08 |

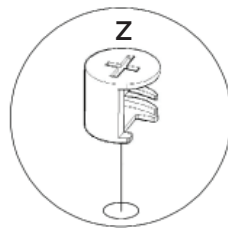
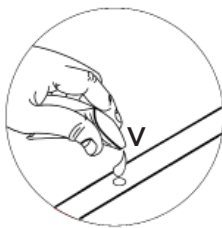
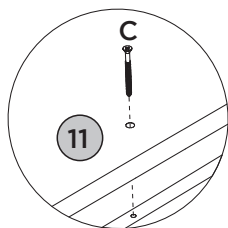
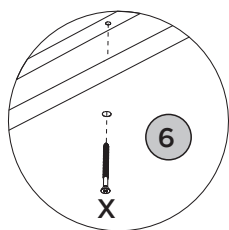
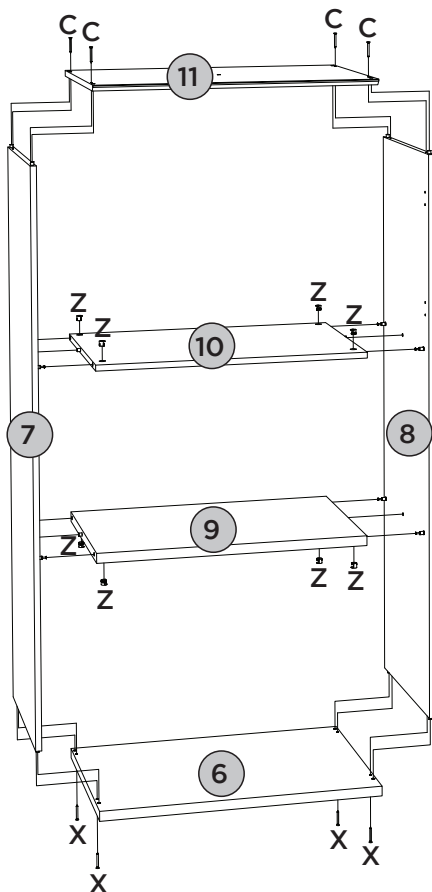
**FERRAMENTAS NECESSÁRIAS**

# PASSO 5

ITM/C643-

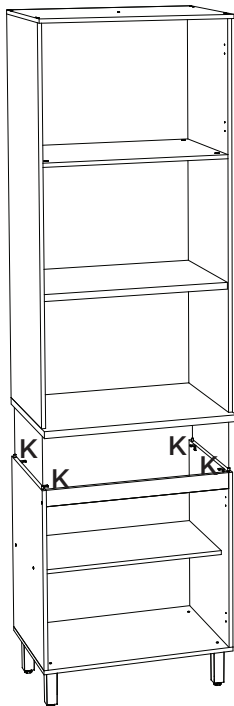

## ACESSÓRIOS REQUERIDOS

|   |  |    |
|---|--|----|
| G |  | 08 |
| K |  | 04 |
| V |  |    |

## FERRAMENTAS NECESSÁRIAS

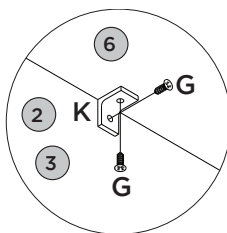

# PASSO 6

## PEÇAS REQUERIDAS

|    |                |    |
|----|----------------|----|
| 12 | FUNDO INFERIOR | x2 |
| 13 | FUNDO CENTRAL  | x2 |
| 14 | FUNDO SUPERIOR | x1 |

## ACESSÓRIOS REQUERIDOS

|   |  |    |
|---|--|----|
| I |  | 80 |
| J |  | 24 |

## FERRAMENTAS NECESSÁRIAS

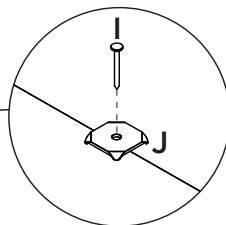
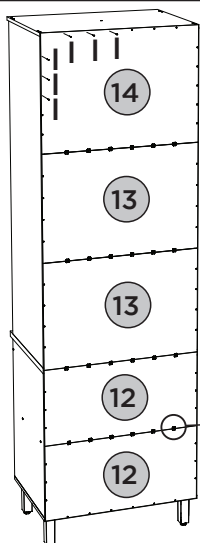
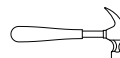

Fixar os pregos a uma distância de 100mm de um para outro.

Fijar las uñas a un distancia de 100mm uno a otro.

Fix the nails at a distance of 100mm from one to the other



## PEÇAS REQUERIDAS

|    |                |    |
|----|----------------|----|
| 15 | PORTA INFERIOR | x2 |
| 16 | PORTA          | x2 |

## ACESSÓRIOS REQUERIDOS

|   |   |    |
|---|---|----|
| G |  | 16 |
| N |  | 08 |



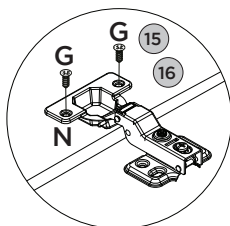
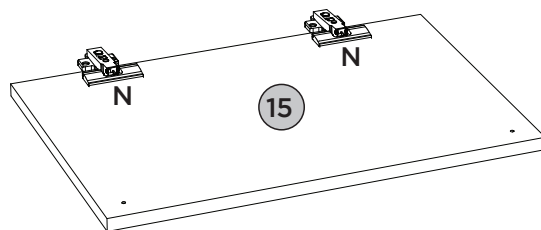
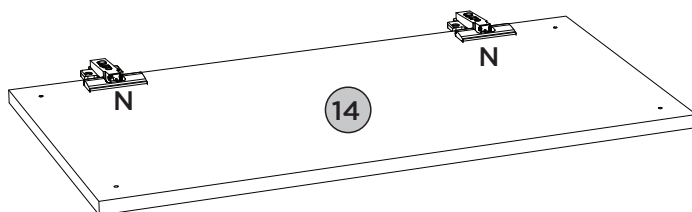
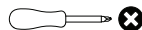



## FERRAMENTAS NECESSÁRIAS



## PEÇAS REQUERIDAS

|    |                |    |
|----|----------------|----|
| 15 | PORTA INFERIOR | x2 |
| 16 | PORTA          | x2 |







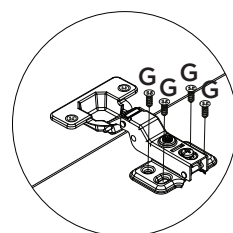
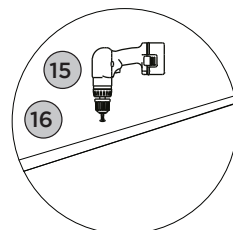
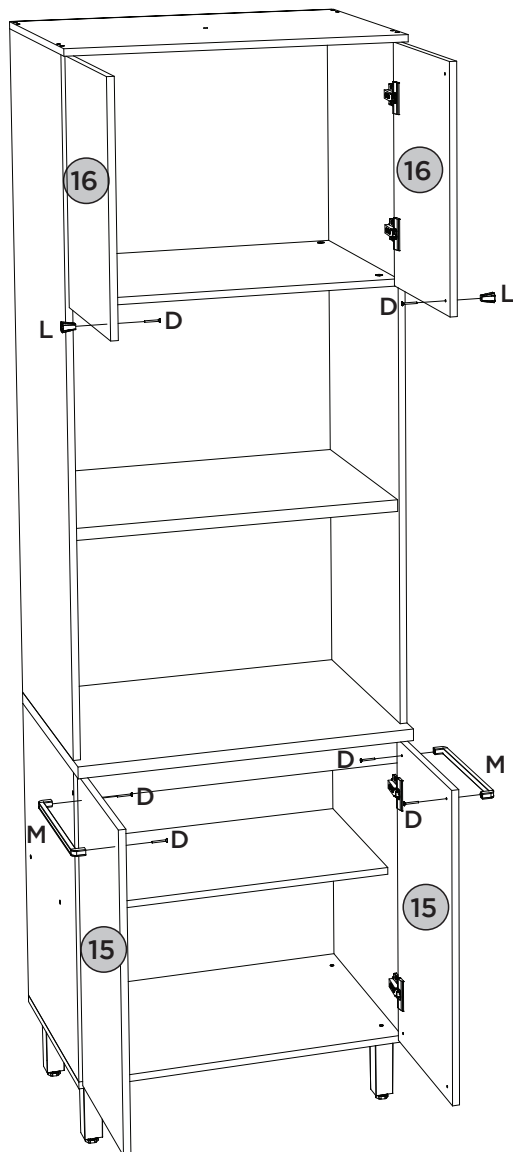
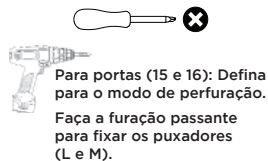

## ACESSÓRIOS REQUERIDOS

|   |   |    |
|---|---|----|
| D |   | 06 |
| G |   | 32 |
| L |    | 02 |
| M |    | 02 |

## FERRAMENTAS NECESSÁRIAS



ACESSÓRIOS REQUERIDOS

|   |   |    |   |   |    |
|---|---|----|---|---|----|
| A |  | 01 | S |  | 16 |
| G |  | 02 | T |  | 12 |
| P |  | 01 | U |  | 03 |
| Q |  | 01 | W |  | 01 |
| R |  | 01 |   |   |    |

FERRAMENTAS NECESSÁRIAS



OU

Para parede: Ajustar no modo perfuração  
Para peça (11): Usar torque 5

Pesos máximos recomendados com carga distribuída  
Peso máximo recomendado con la carga distribuida  
Recommended maximum weight with distributed load.

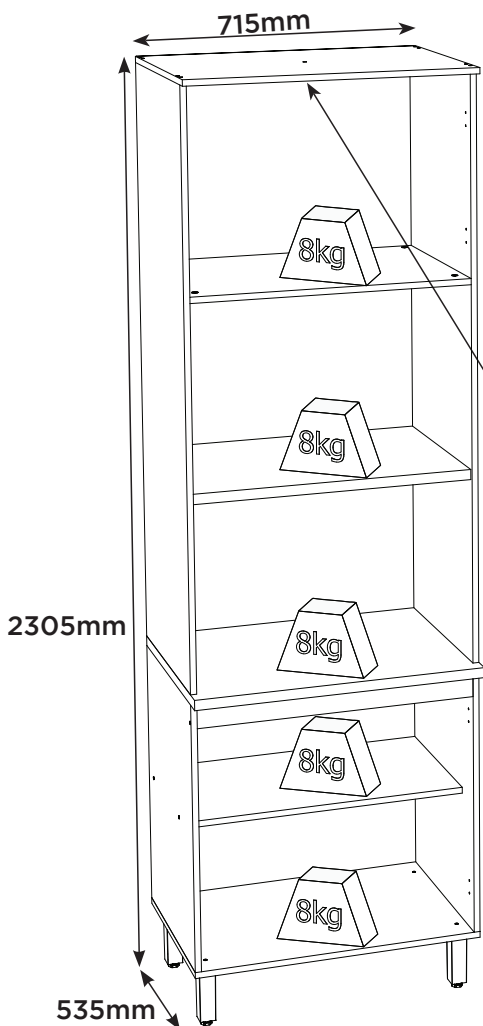

PERFECT CORRECTION  
CORRECCIÓN PERFECTA

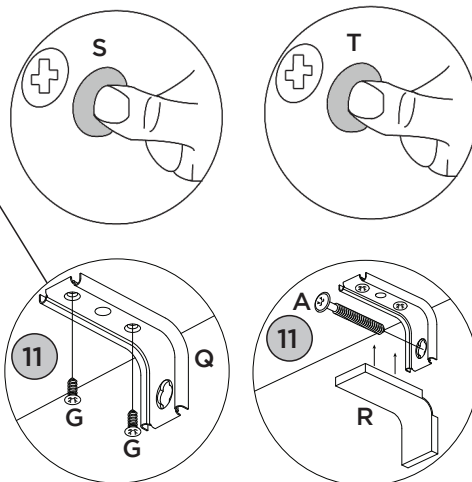
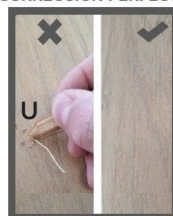

RECOMENDAÇÃO

Para fixar o móvel na parede usar o suporte de fixação (Q), o parafuso 4,0x14mm CHT (G), a Bucha 8mm (P) e o parafuso 5,0x50mm FLA (A).

RECOMENDACIÓN

Para conectar el móvil a la pared con el soporte (Q), tornillo 4,0x14mm CHT (G), el casquillo de 8 mm (P) y el 5,0 x50mm tornillo FLA (A).

RECOMMENDATION

To fix the furniture to the wall use the fixing bracket (Q), the 4,0x14mm CHT (G) screw, the 8mm bushing (P) and the 5.0x50mm FLA screw (A).

**Produto Concluído**  
**Producto terminado**  
**Finished Product**

